

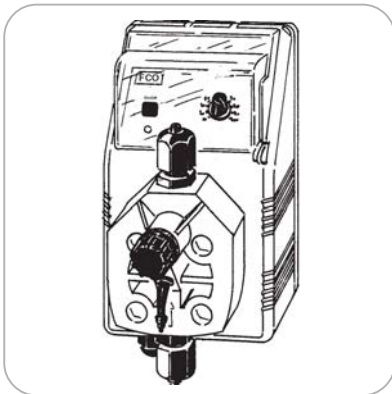

This operating instructions contains safety information that if ignored can endanger life or result in serious injury. They are indicated by this icon.



Use of this pump with radioactive chemicals is forbidden!



OPERATING INSTRUCTIONS MANUAL FOR “F” and “FA” PUMPS



Keep the pump protected from sun and water.
Avoid water splashes.

Read Carefully!



English language

R1-06-06



“F” and “FA” series solenoid dosing pumps comply with the following European regulations:

EN60335-1 : 1995, EN55014, EN50081-1/2, EN50082-1/2, EN6055-2, EN60555,3

Based on directive CEE 73/23 c 93/68 (DBT Low voltage directive) and directive 89/336/CEE (EMC Electromagnetic Compatibility)



GENERAL SAFETY GUIDELINES

Danger!

In emergencies the pump should be switched off immediately! Disconnect the power cable from the power supply!

When using pump with aggressive chemicals observe the regulations concerning the transport and storage of aggressive fluids!

When installing always observe national regulations!

Manufacturer is not liable for any unauthorized use or misuse of this product that may cause injury, damage to persons or materials.

Caution!

Pump must be accessible at all times for both operating and servicing. Access must not be obstructed in any way!

Feeder should be interlocked with a no-flow protection device.

Pump and accessories must be serviced and repaired by qualified and authorized personnel only!

Always discharge the liquid end before servicing the pump!

Empty and rinse the liquid end before work on a pump which has been used with hazardous or unknown chemicals!

Always read chemical safety datasheet!

Always wear protective clothing when handling hazardous or unknown chemicals!

Introduction:

“F” and “FA” Series metering pumps are the ideal solution for low / middle dosing of chemicals. All control and setup parameters are available using accurate control knobs and a visual system (led). “F” and “FA” Series metering pumps have digital On/Off switch to ensure dosing activities (available on some models only).

Pump capacity:

Flow rate is determined by the stroke speed (frequency) adjustment. The stroke speed is adjustable from 0 to 100% using the adjustment knob. However dosing accuracy is guarantee within an adjustment range from 30% to 100%. The led on the panel shows the status activity of the pump.

2. Unpacking

Included into package:

- n.2 Dibbles $\varnothing 6$
- n.2 Self tapping screws 4,5 x 40
- n.1 Delayed fuse 5 X 20
- n.1 Foot filter with valve
- n.1 Injection valve
- n. 1 Level probe (not included in FCO and FPDR model)
- m 2 Delivery pipe* (opaque PE)
- m 2 Suction pipe * (transparent PVC)
- m 2 Discharge pipe (transparent PVC 4x6)
- n.1 This installation manual

* If hose is 6x8 then there is only a 4mt long hose.
Cut to obtain suction and delivery hoses.

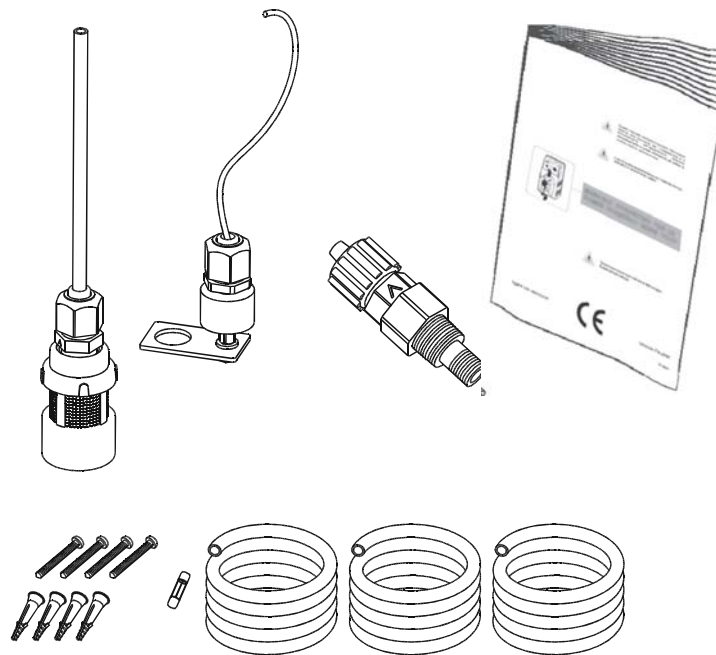

**PLEASE DO NOT TRASH PACKAGING.
IT CAN BE USED TO RETURN THE PUMP.**

3. General description

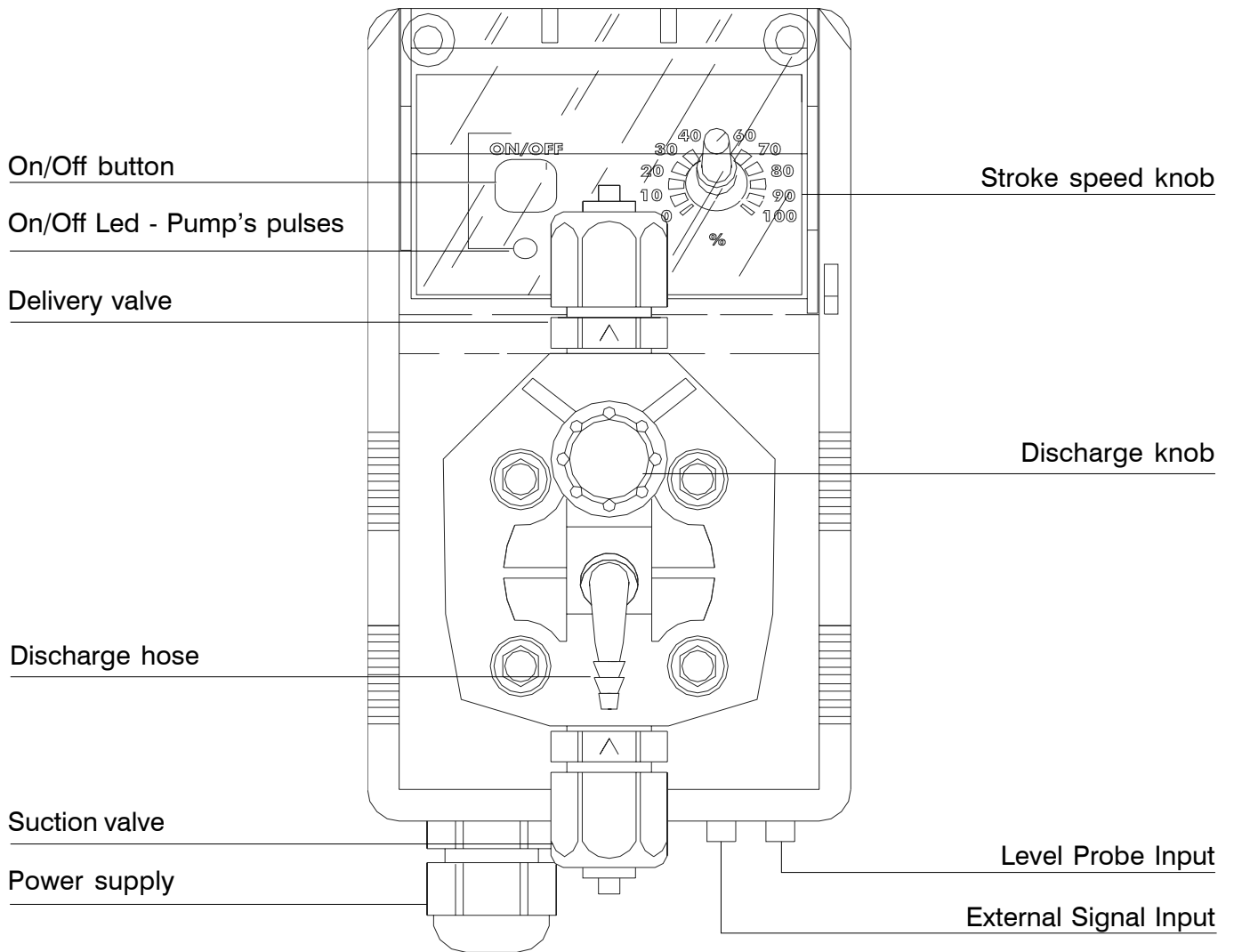

Note:

Shown image does not represent a specific pump's model. It is only for general purpose.

4. Before to Install warnings

Pump's installation and operativity is performed in 4 main steps:

Pump's installation

Hydraulic Installation (hoses, level probe, injection valve)

Electrical Installation (main power connection, priming)

Programming the pump.

Before to start, please read carefully the following safety information.

Protective clothes



Wear always protective clothes as masks, gloves, safety glasses and further security devices during ALL installation procedure and while handling chemicals.

Installation location



Pump must be installed in a safety place and fixed to the table / wall to avoid vibration problems!

Pump must be installed in a easy accessible place!

Pump must be installed in horizontal position!

Avoid water splashes and direct sun!

Hoses and Valves



*Suction and delivery hoses must be installed in horizontal position!
All hoses connections must be performed using only hands' force!
No tongs required!*

Delivery hose must be firmly fixed to avoid suddenly movements that could damage near objects!

Suction hose must be shorter as possible and installed in vertical position to avoid air bubbles suction!

Use only hoses compatibles with product to dose! See chemical compatibility table. If dosing product is not listed please consult full Compatibility Table or contact chemical's manufacturer!

5. Installation draw

Pump must be installed in a stable support at a maximum height (from tank's bottom) of 1,5 meters.

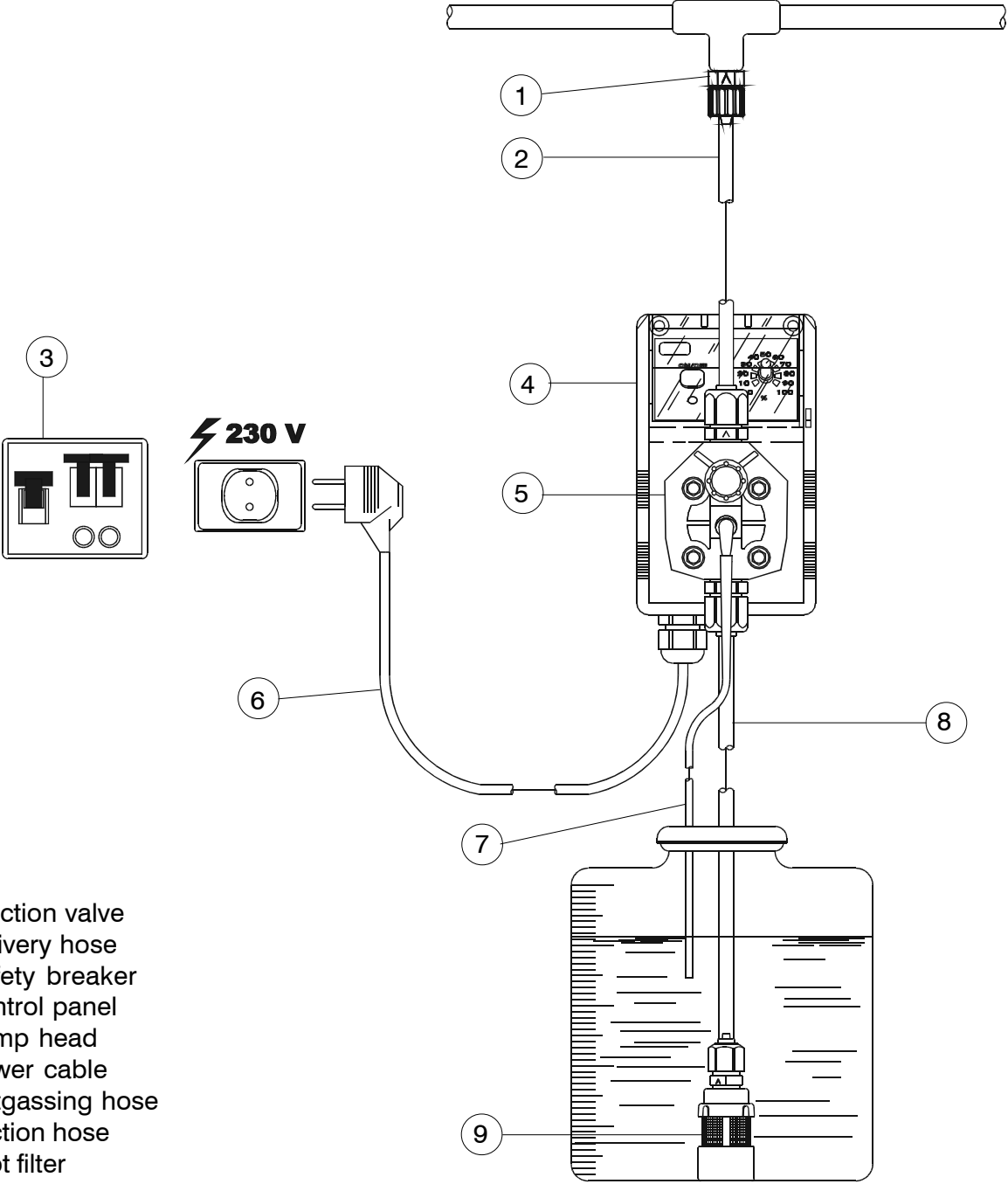

- 1. Injection valve
- 2. Delivery hose
- 3. Safety breaker
- 4. Control panel
- 5. Pump head
- 6. Power cable
- 7. Outgassing hose
- 8. Suction hose
- 9. Foot filter

6. Hydraulic Installation

Hydraulic connections are:

Suction Hose with level probe and foot filter
Delivery Hose with injection valve
Discharge Hose

Suction Hose.

Completely unscrew tightening nut from pump's head and remove assembling components: *tightening nut, holding ring and pipe holder.*

Assembly as shown in fig. (A). Insert hose into pipe holder until it reaches the bottom.

Lock hose on pump's head by screwing down the tightening nut.
Use only hands to do it!

Connect other side of the hose to the foot filter using the same procedure.



fig. (A)

Assembling foot filter with level probe.

Level probe must be assembled with foot filter using the provided kit. Foot valve is made to be installed into tank's bottom without sediments priming problem.

Completely unscrew level probe's nut and assembly as described in fig. (B) **paying attention to the black ring: it must be inserted from floater side.** Lock nut on the opposite side of the floater using hands only.

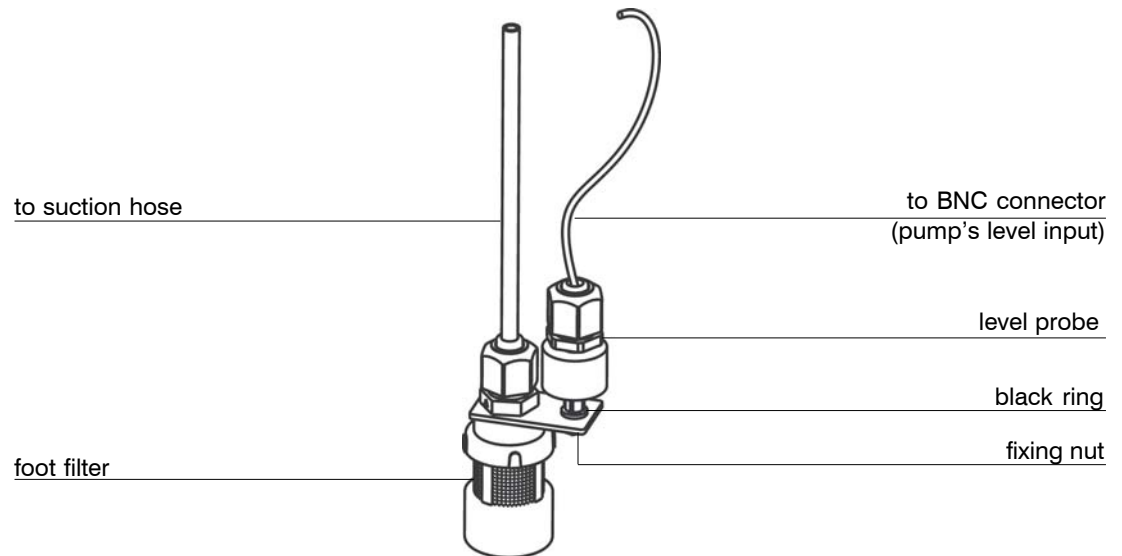

fig. (B)

Connect BNC from level probe into pump's level input (front side of the pump). Put level probe assembled with foot filter into tank's bottom.

Warning: If there is a mixer installed into tank, install a suction lance instead of level probe / foot filter.

Delivery Hose.

Completely unscrew tightening nut from pump's head and remove assembling components: *tightening nut, holding ring and pipe holder.*

Assembly as shown in fig. (A). Insert hose into pipe holder until it reaches the bottom.

Lock hose on pump's head by screwing down the tightening nut. Use only hands to do it!

Connect other side of the hose to the injection valve using the same procedure.

6. Hydraulic installation

Injection Valve.

Injection valve must be installed on plant from water's input.
Injection valve will open at pressure greater than 0,3bar.

Discharge hose.

Insert one side of discharge hose into discharge connector as shown in fig (C).

Insert other side of discharge hose into product's tank.
During priming procedure product exceeding will flow into tank.

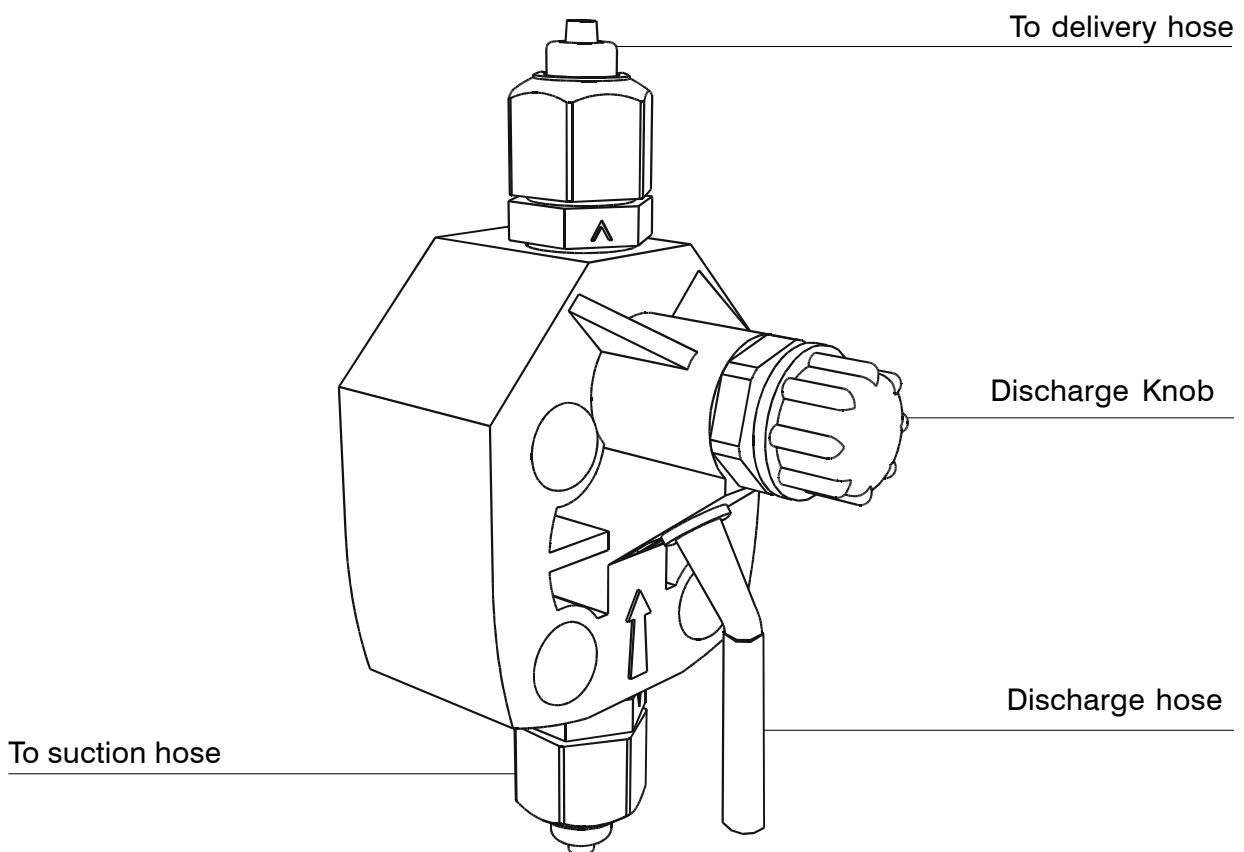
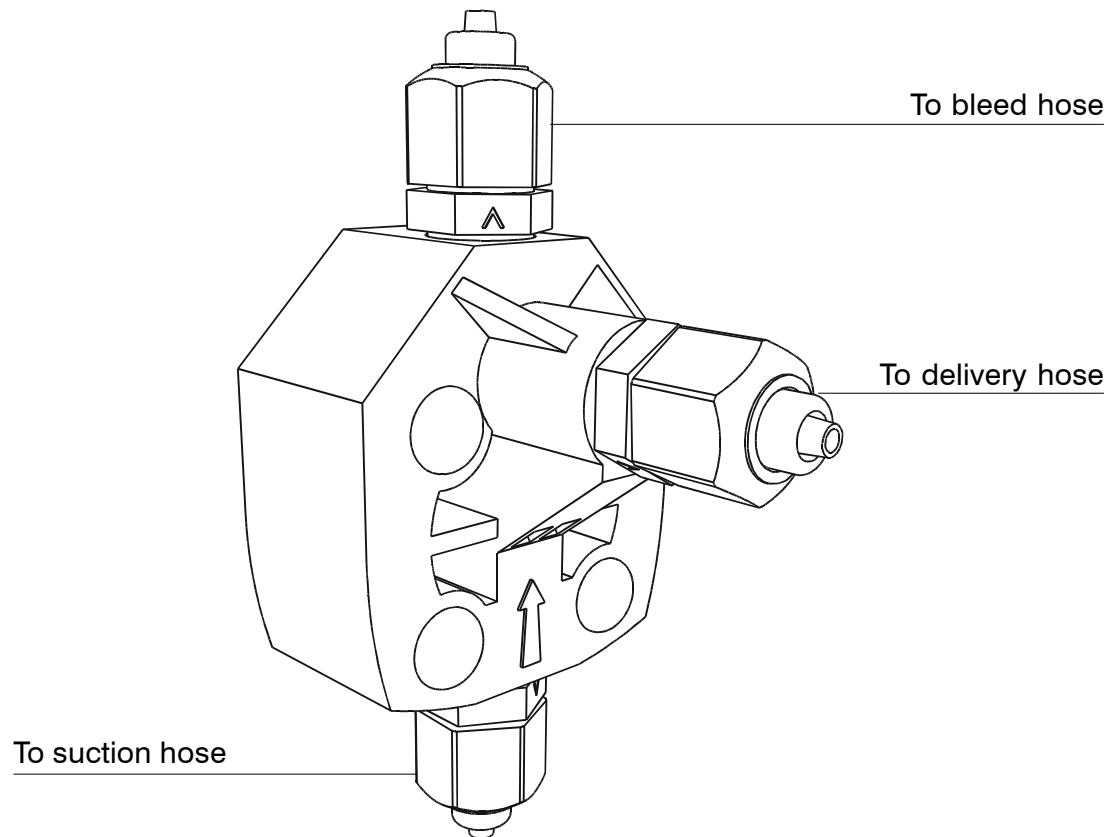

fig. (C)

For priming procedure see the related chapter.

Self-venting pump head.



Self-venting pump head must be used when using chemicals that produce gas (i.e. hydrogen peroxide, ammonium, sodium hypochlorite at particular conditions).

Hoses assembling procedure (*including purge hose*) is described in fig. (A).

Notes:

- suction, delivery and purge valves are DIFFERENT! Do not exchange them!
- delivery and purge hoses are made of same material!
- it's allowed to lightly bend discharge hose!
- during calibration procedure ("TEST") insert discharge hose into BECKER test-tube!

7. Electrical installation

All electrical connections must be performed by **AUTHORIZED AND QUALIFIED** personnel only. Before to proceed, please, verify the following steps:

- verify that pump's label values are compatible with main power supply.
- pump must be connected to a plant with a differential switch (0,03A sensitivity) if there isn't a good ground.
- to avoid damages to the pump do not install it in parallel with heavy inductance load (for example: engines). A relay switch must be used. See below picture.

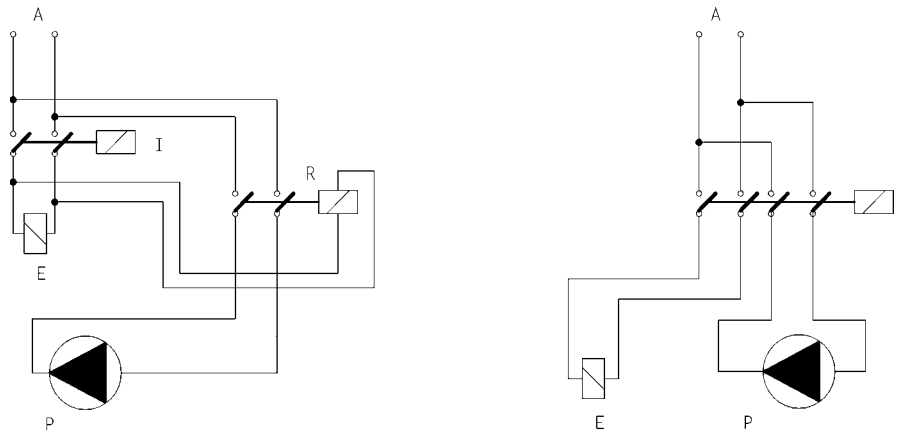

P - Dosing Pump
R - Relay
I - Switch or safety device
E - Electrovalve or inductance load
A - Main Power

- On pump's mother board there is a further protection against over voltages (275V - 150V) and distribution line noises (4KV for max 50 μ sec) as shown:

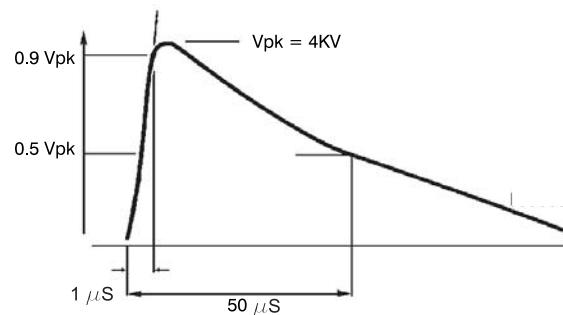

Once verified previous steps proceed as follows:

- check that “BNC” of level probe has been connected as described in “Hydraulic Installation” chapter.
- connect “BNC” and external signal to pump’s “INPUT” connectors.

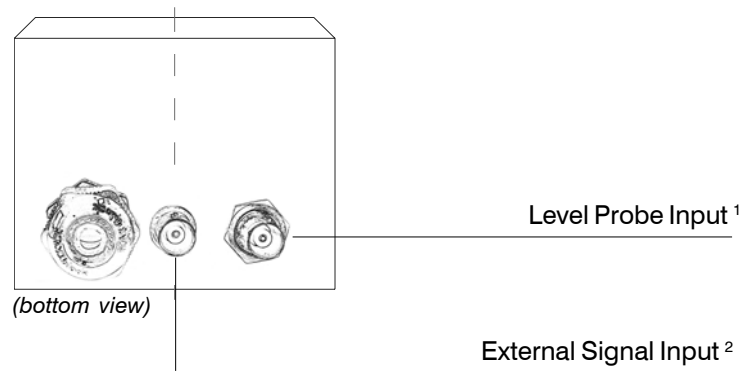

¹ Level Probe Input available on: FTE, FPDR, FIC, FIS, FPV, FPVM, FCL

² External Signal Input available on: FPDR (optional), FIC, FIS, FPV, FPVM, FTE

8. Models

LEVEL ALARM

CL, IS, IC, PV, TE and PVM type pump are provided with a liquid level alarm to indicate product tank is empty. The level probe is connected to the right BNC plug on pump's bottom panel. The level probe is made of a N.O. reed contact (10VA, 1A max., 230Vac max.) closed by a floating magnet housed in a (PP) plastic box. When the product level goes below the minimum the magnet closes the reed contact. The pump stops and the red LED on pump's front panel indicates the alarm status.

PUMP TYPES

Pumps mod. "FCL" (12-24 Vac/Vdc), "FIC", "FIS", "FPV" and "FPVM" are equipped with a bicolour led.

Led on, red colour: low level product alarm. Check product's tank and restore the level.

Led on, blinking green colour: pump normal operating mode.

Led on, blinking green colour (one second on, one second off): power supply out of range. Check pump's label and check the main power.

FCO

Constant pump with flow control (front panel knob may be set from 0% to 100% of pump nominal capacity). Flow control is electronically set and it operates on pump injections number. To avoid linearity problem do not set the knob of pump flow between 0% and 10%.

FCO may operate in constant dosing mode or On-Off mode (using an external signal).

Dosing example using an FCO 0505: to dose 2,5 l/h at 5bar counter-pressure rotate front panel knob to 50%.

FCO has a divider (x- 0,1) to reduce by ten times the pump capacity by dividing the pump stroke speed.

How to enable "divider mode":

- set the pump into STANDBY* mode;
 - keeping pressed the on/off button, wait 3 flashes from the status led. The pump will start the dosing activity with the stroke speed reduced ten times than the value set on stroke lenght knob.
- To disable the "divider mode", power OFF the pump. Keeping pressed the on/off button, wait 3 flashes of the status led.

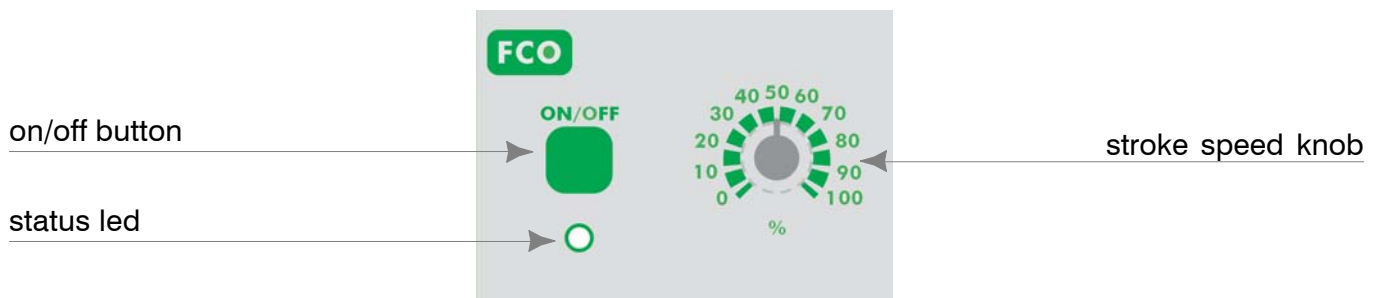

STATUS LED

The led on the frontal panel shows the pump's operating status through four flashing:

LED ACTIVITY	PUMP'S STATUS
It flashes 3 times per second	the pump is powered with a power supply lower than the label
It flashes 2 times per second	the pump is powered with a power supply higher than the label
It flashes 1 time per second	the pump is in pause (OFF) and it is powered (STANDBY* mode)
led ON, it switches off 1 time per second	the pump is active and functioning (ON)

8. Models

FCL

Constant dosing pump with level alarm.

A red led indicates that the product's tank is empty. During this condition the pump does not dose. The pump has flow control (front panel knob may be set from 0% to 100% of pump nominal capacity). Flow control is electronically set and it operates on pump injections number. To avoid linearity problem do not set the knob of pump flow between 0% and 10%.

FCL has a divider (x- 0,1) to reduce by ten times the pump capacity by dividing the pump stroke speed.

How to enable "divider mode":

- set the pump into STANDBY* mode;
 - keeping pressed the on/off button, wait 3 flashes from the status led. The pump will start the dosing activity with the stroke speed reduced ten times than the value set on stroke lenght knob.
- To disable the "divider mode", power OFF the pump. Keeping pressed the on/off button, wait 3 flashes of the status led.

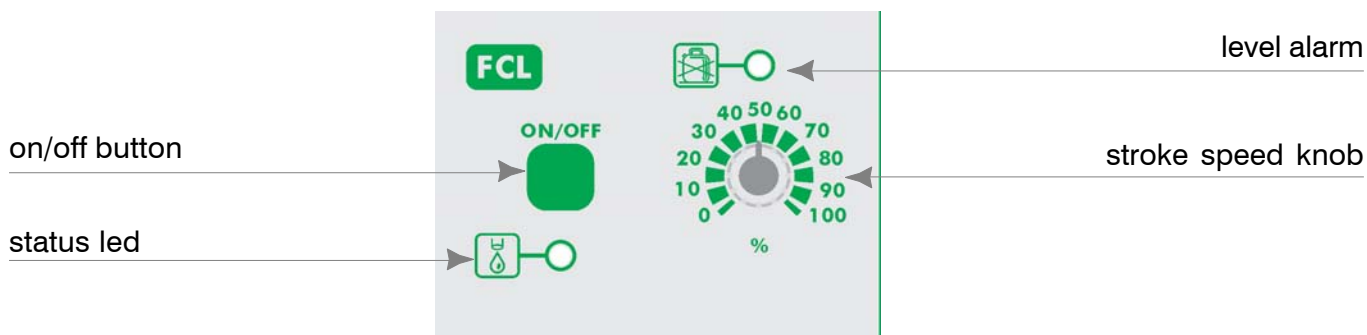

STATUS LED

The led on the frontal panel shows the pump's operating status through four flashing:

LED ACTIVITY	PUMP'S STATUS
It flashes 3 times per second	the pump is powered with a power supply lower than the label
It flashes 2 times per second	the pump is powered with a power supply higher than the label
It flashes 1 time per second	the pump is in pause (OFF) and it is powered (STANDBY* mode)
led ON, it switches off 1 time per second	the pump is active and functioning (ON)

FIC

Proportional/constant pump driven by a current signal.

Setting the switch on *constant*  position, the pump has flow control (front panel knob may be set from 0% to 100% of pump nominal capacity). Flow control is electronically set and it operates on pump injections number. To avoid linearity problem do not set the knob of pump flow between 0% and 10%.

Setting the switch on the *proportional*  position, the pump capacity is set proportionally to analog current input signal; a signal change will be followed by a linear change of pump's capacity.

The current range is 0÷20 mA (0 dosing, 20 max dosing).

The maximum pump capacity for maximum input signal is set by the % marked knob.

The FIC pump can be controlled by any electronic device (such as pH-meter, redox-meter, etc) that has an analog current signal output. This signal must be applied to the bipolar cable provided with the pump, using the following connections:

- Red wire : *positive (+)*
- Black wire : *negative (-)*

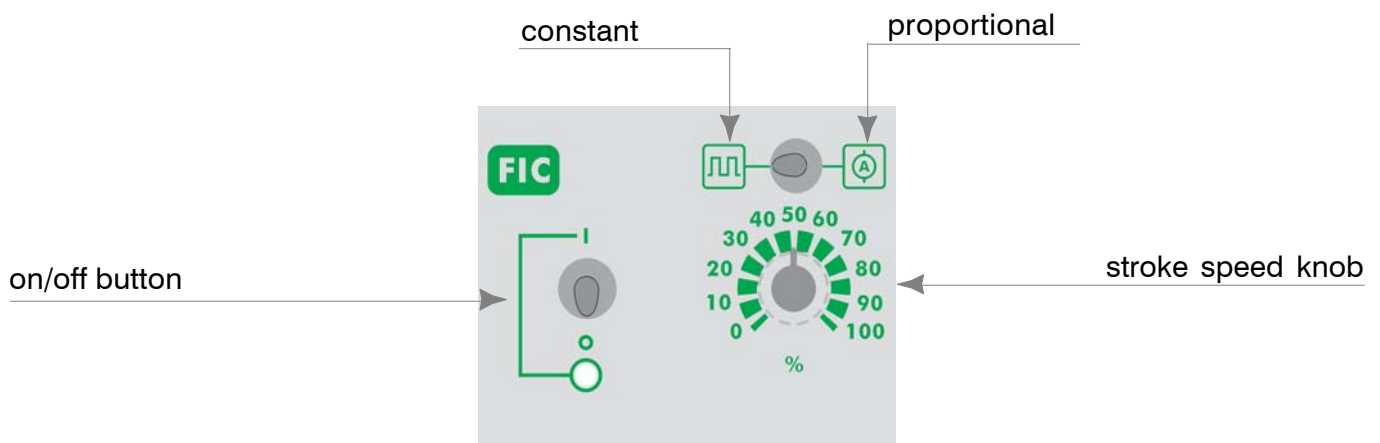

8. Models

FIS

Proportional/constant pump driven by a digital signal.

Setting the switch on *constant*  position, the pump has flow control (front panel knob may be set from 0% to 100% of pump nominal capacity). Flow control is electronically set and it operates on pump injections number. To avoid linearity problem do not set the knob of pump flow between 0% and 10%.

Setting the switch on the front panel in the *proportional*  position, for each external “voltage free” pulse corresponds a magnet stroke.

If proportional position is set, then the % marked knob does NOT affect the pump capacity.

FIS proportional dosing pump can be driven by any external device (such as PCs, PLCs, etc) that has a digital signal. This digital signal (N.O. contact) must be applied to the cable provided with the pump. Connect a 0÷5 or 0÷12 Vdc input signal option using the following connections:

- Red wire : *positive (+)*
- Black wire : *negative (-)*

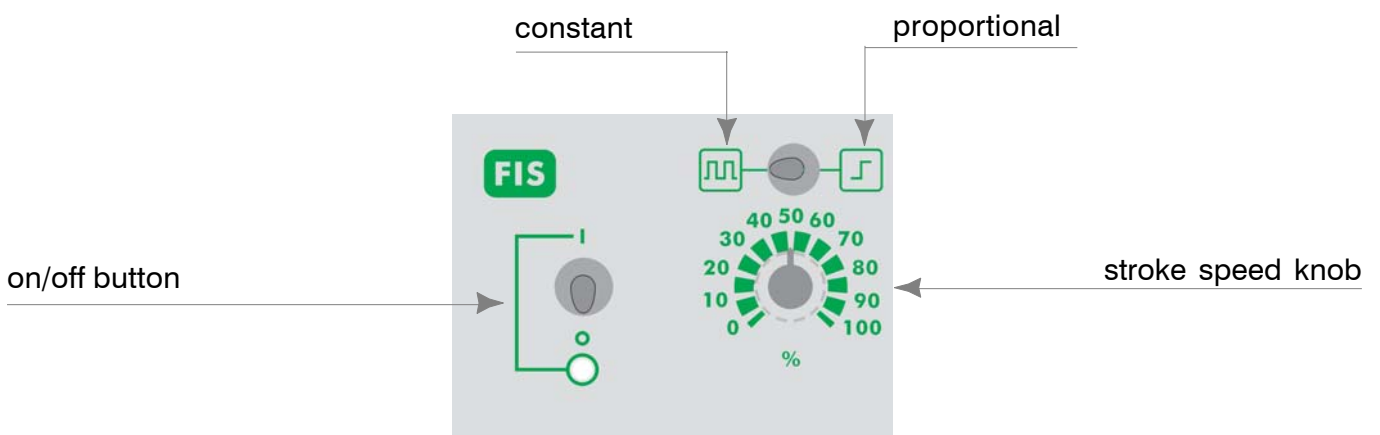

FPV

Proportional/constant pump driven by a water meter digital signal.

Setting the switch on *constant*  position, the pump has flow control (front panel knob may be set from 0% to 100% of pump nominal capacity). Flow control is electronically set and it operates on pump injections number. To avoid linearity problem do not set the knob of pump flow between 0% and 10%. It is furthermore possible to divide the maximum magnet strokes per minute by 1, 10 and 100 using the switch on the front panel.

Setting the switch on *proportional*  position, for each external pulse corresponds one pump stroke. This pump can be driven by a CTFI or CWFI series water meters.

This pump can also be driven by a digital signal coming from a “voltage free” contact. Driving signal is applied on the BNC plug on the left bottom of front cover. Dividing factor (N) value is obtained multiplying the value on the adjustment knob using the multiplying switch (x1, x10, x100).

Capacity definition for “FPV” and “FAPV” pump

Use the following formula to obtain minimum pump capacity:

$$\frac{\text{ppm} \times K \times m^3}{1000} = l/h$$

l/h - minimum pump capacity required

ppm - product amount to dose in p.p.m. (gr/m³)

k - dosed product dilution factor (pure chemical *k*=1)

m³ - maximum capacity of system to be treated in m³/h.

Dividing factor (N) to set on adjustment knob:

$$\left(\frac{\text{imp/l} \times \text{cc}}{\text{ppm} \times K} \right) \times 1000 = N$$

N - number of the external pulses are divided to be set on adjustment knob

imp/l - pulse per liter given by the water meter

cc - pump's single stroke dosing quantity (in cc). Refer to following table

k - dosed product dilution factor (pure chemical *k*=1)

ppm - product quantity to be dosed in p.p.m. (gr/m³)

8. Models

<i>Fxx</i>	cc	<i>FAxx</i>	cc
12 1,5	0,17	10 3,2	0,35
10 05	0,56	10 0,6	0,07
10 2,2	0,25	07 1,5	0,17
07 03	0,34	05 3,2	0,35
07 05	0,56	03 6,5	0,72
06 06	0,67	03 4,7	0,52
05 10	1,11		
05 07	0,78		
05 05	0,56		
05 0,2	0,23		
03 11	1,22		
03 8,5	0,94		
03 6,5	0,72		

If dividing factor (N), obtained with the formula, is <1 , a pump with higher single stroke dosing quantity is required or the water meter needs to be changed with one that gives higher number of pulses per liter (using a “FPVM” or “FAPVM” pump). In some application this issue can be solved reducing the dosed product dilution factor. If dosed amount is higher than the needed one, then increase the set dividing factor (N).

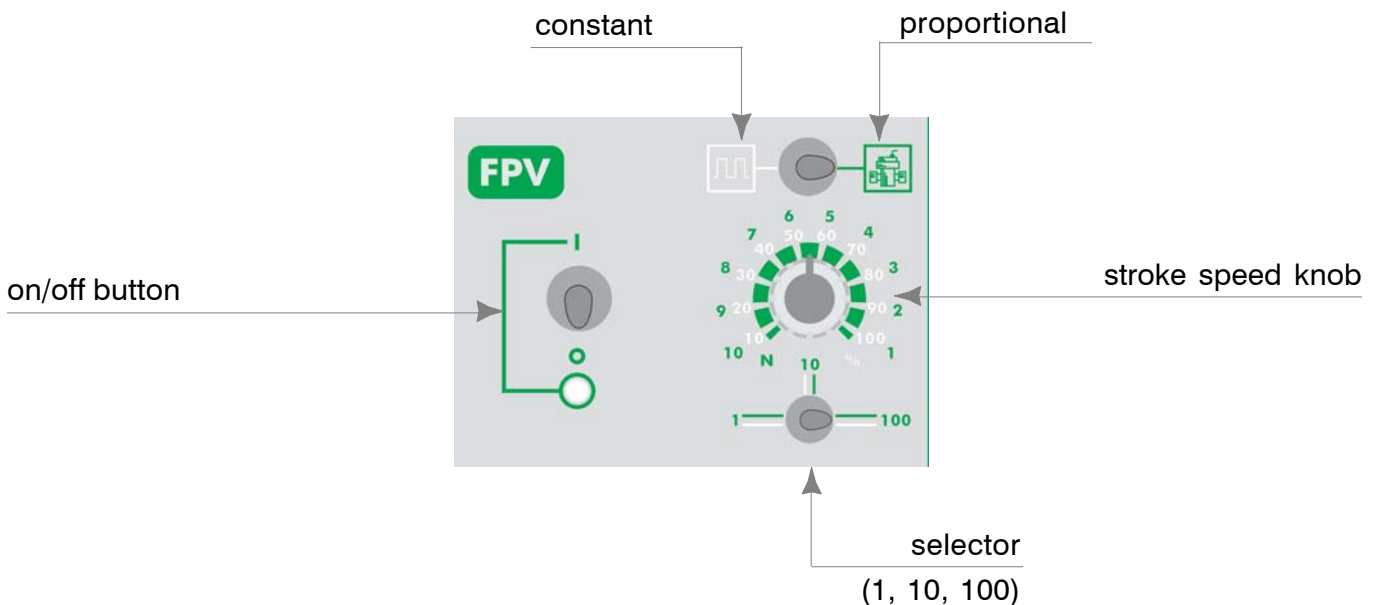

FPVM

Proportional/constant pump driven by a water meter digital signal.

Setting the switch on *constant*  position, the pump has flow control (front panel knob may be set from 0% to 100% of pump nominal capacity). Flow control is electronically set and it operates on pump injections number. To avoid linearity problem do not set the knob of pump flow between 0% and 10%.

It is furthermore possible to divide the maximum magnet strokes per minute by 1 ($\div 1$), 10 ($\div 10$) and 100 ($\div 100$) using the selector on the front panel. The electronic capacity adjustment sets the injection per minute.

Setting the switch on the *proportional*  position and the selector on “multiplier” (X1), the pump gives a stroke each 10 external pulses sent. Setting the selector on “divider” ($\div 1$ or $\div 10$), the pump gives at maximum a stroke each external pulse sent and at minimum a stroke each 100 pulses sensed (knob $n=10$, switch $\div 10$).

This pump can be driven by a CTFI or CWFI series water meters. This pump can also be driven by a digital signal coming from a voltage free contact. Driving signal is applied on the BNC plug on the left of the bottom pump cover. “FPVM” and “FAPVM” capacities are defined by the same formulas used for “FPV” and “FAPV”.

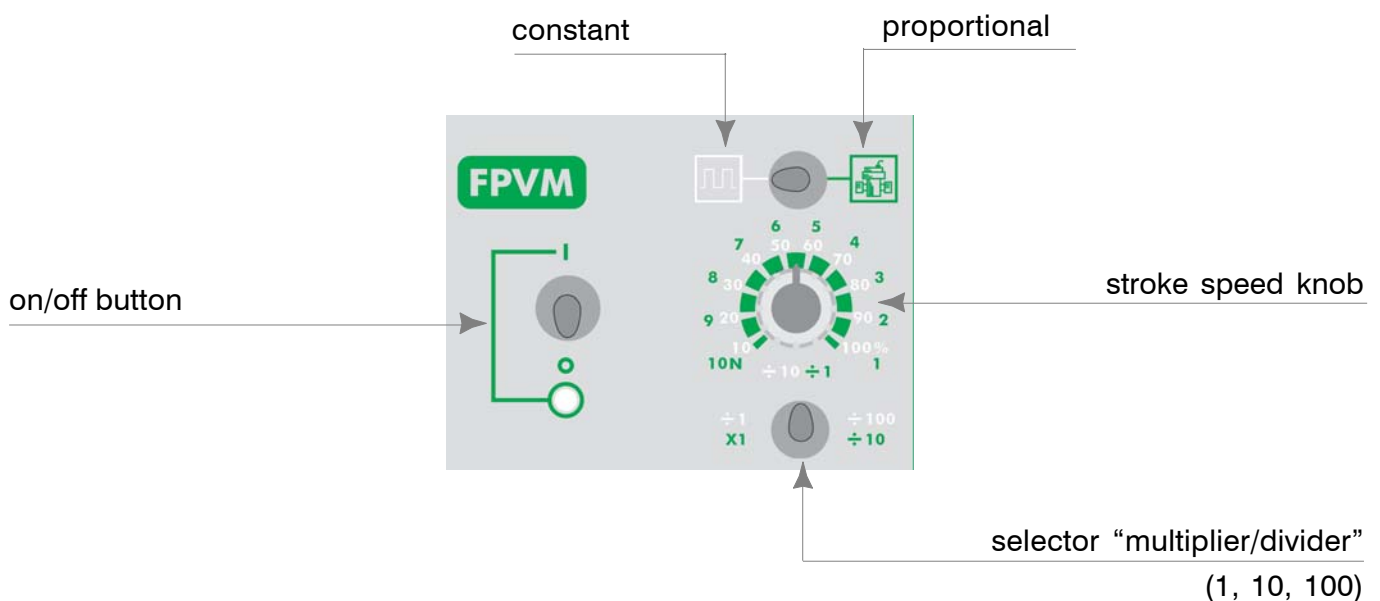

8. Models

FTE

Timered/constant dosing pump.

Setting the switch on the *constant*  position, the pump has flow control (front panel knob may be set from 0% to 100% of pump nominal capacity). Flow control is electronically set and it operates on pump injections number. To avoid linearity problem do not set the knob of pump flow between 0% and 10%.

Setting the switch on *timered* , the pump starts working when an external pulse is provided. Working active time for each external pulse is set on the adjustment knob in the range between 0 and 60 seconds (different time are available upon demand).

The capacity can be also changed adjusting the stroke per minute, operating the % marked knob, at the same time.

The double parameter adjustment (strokes and time) allows the use of this pump in high capacity systems, where the pulses are not enough to drive a PV type pump.

TE pump is provided of a coaxial cable (RG58) with BNC plug to connect the command signal.

Use following formula to evaluate the knob adjustment:

$$\frac{3600}{\text{imp/h}} = \text{sec.}$$

imp/h - water meter output pulse per hour
sec - time in seconds to be set on time knob

Maximum tag capacity can be decreased 10 or 100 times in the “F” and “FA” pumps using the 1/10/100 switch (where available). In that case the % marked knob will work on the maximum set capacity.

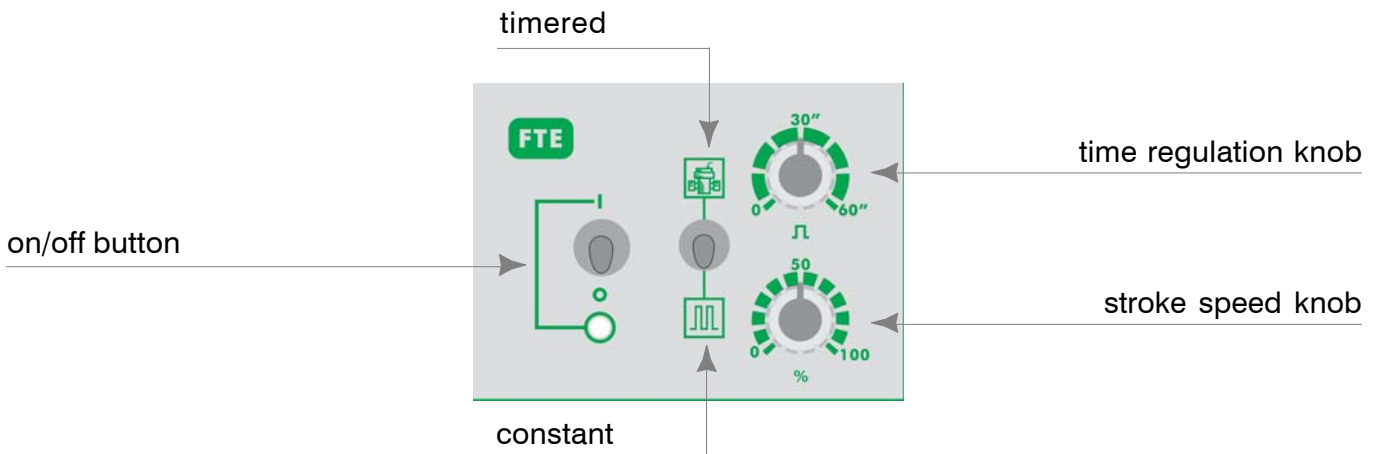

FPDR

Intermittent constant metering pump with adjustable pause and work times.

Metering is set using three knobs on the front panel:

- (%) knob (red coloured range) sets speed stroke
- (10÷180 seconds) Pause knob sets time between one metering and the next
- (10÷180 seconds) Work knob sets metering time

Once powered the pump, it always starts its working cycle metering for the set time.

The pump can be provided with a N.O. (1A / 230Vac) service contact: this contact is active while metering. If the level input is active while the service contact is active, pump stops and service contact gets back to N.O.

Service contact is available through a bipolar cable out of the pump.

Once refilled the tank or recovered the level input, the pump starts to dose for the remaining time missing to complete the set work time once stopped.

Level alarm is showed on the front panel with a red LED on.

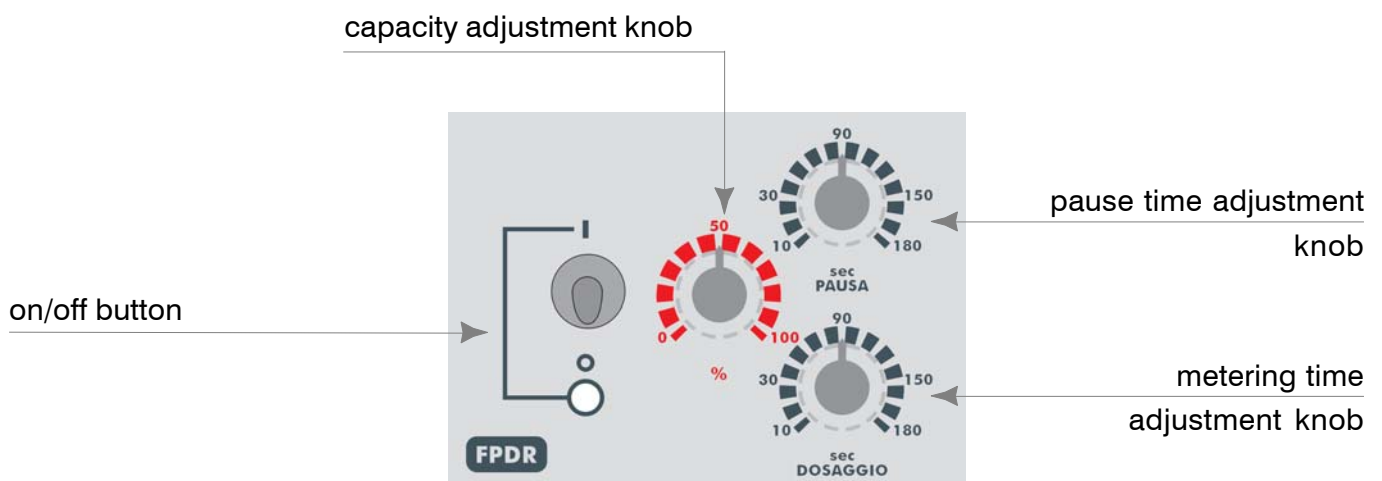

9. Priming

MANUAL PRIMING / DISCHARGING

1. Connect the pump to main power.
2. Rotate front panel knob to 70%.
3. Turn on the pump.
4. Rotate discharge knob (open it completely).
5. The chemical will begin to flow into discharge hose. Close the discharge knob.
6. Proceed to normal operating mode.

PROBLEM	POSSIBLE CAUSE
<p>Pump doesn't turn on.</p>	<p><i>Pump isn't powered. Connect it to main supply.</i></p> <p><i>Pump's protection fuse is broken. Replace it. See page 26 for replacement procedure.</i></p> <p><i>Pump's main board is broken. Replace it. See page 26 for replacement procedure.</i></p>
<p>Pump is not dosing and solenoid is operating.</p>	<p><i>The foot filter is obstructed. Clean it.</i></p> <p><i>Suction hose is empty. Pump must be primed. Repeat priming procedure.</i></p> <p><i>Air bubbles inside hydraulic circuit. Check valves - hoses - fittings.</i></p> <p><i>Product to dose is generating gas. Turn discharge knob and let air flow away.</i></p> <p><i>Use a self-venting pump head.</i></p>
<p>Pump is not dosing and solenoid isn't operating or slightly operating.</p>	<p><i>Crystals presence inside valves. Check them and try to dose 2-3 liters of normal water. Change valves.</i></p> <p><i>Injection valve obstructed. Change it.</i></p>

11. Fuse and main board replacement

Fuse or main board replacement is allowed to qualified personnel only. Before to operate disconnect the pump from main power and all hydraulic connections.

For fuse replacement is necessary to use a 3x16 and 3x15 screwdriver and a new fuse (same model of old one).

For main board replacement is necessary to use a 3x16 and 3x15 screwdriver and a new main board (same model of old one).

Fuse replacement procedure:

- Turn pump's injection knob on 0%.
- Remove 6 screws from pump's back.
- Pull pump's back cover until it's completely separated from pump's front. Be careful of the knob's spring.
- Locate the blown fuse and replace it.
- Reassemble the pump. Be careful to put back the knob's spring.
- Reinsert screws.

Main board replacement procedure:

- Turn pump's injection knob on 0%.
- Remove 6 screws from pump's back.
- Pull pump's back cover until it's completely separated from pump's front. Be careful of the knob's spring.
- Remove board's screws.
- Completely disconnect wires from main board and replace it. Reinsert screws.
- Reconnect wires to the main board (see enclosed picture).
- Reassemble the pump. Be careful to put back the knob's spring.
- Reinsert screws.

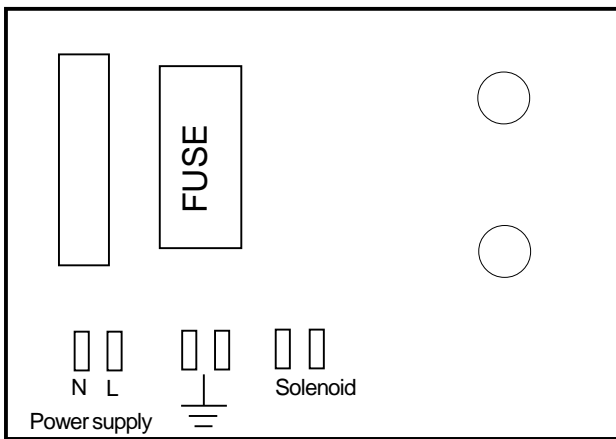

Mod. FCO

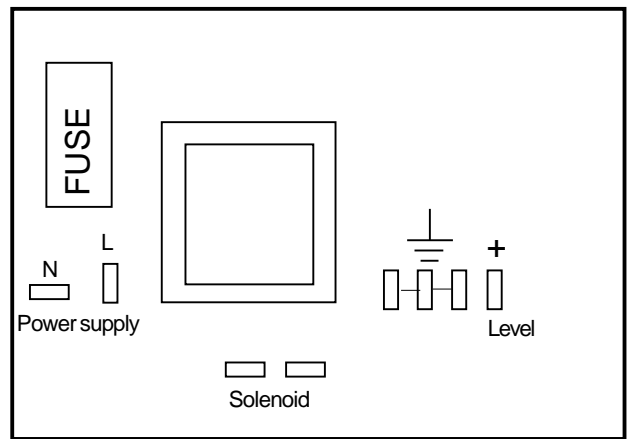

Mod. FCL

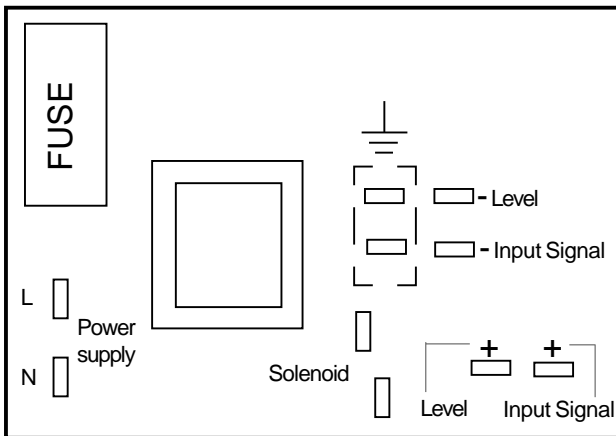

Mod. FIC/FIS

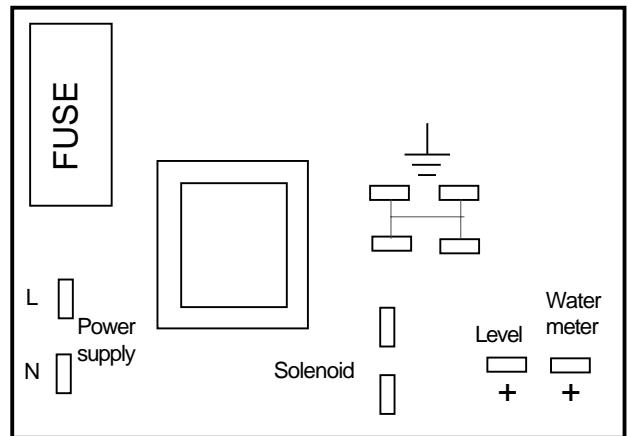

Mod. FPV/FPVM

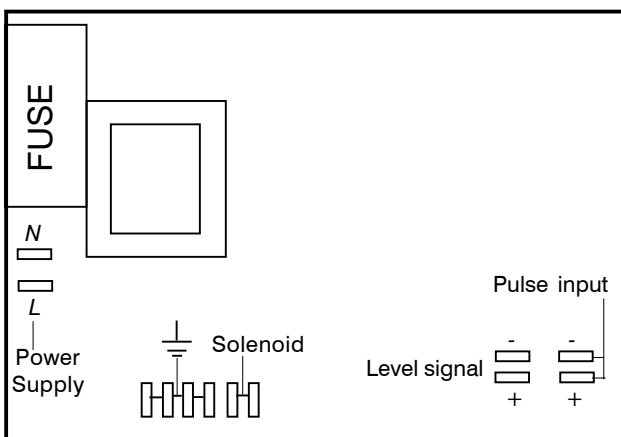

Mod. FTE

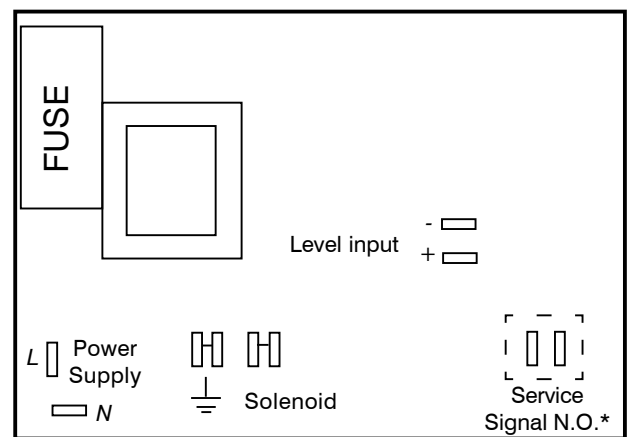

Mod. FPDR

* Service Signal N.O.: optional

12. Main board

Model	Consumption at 230 and fuse	Consumption at 115 and fuse	Consumption at 24 and fuse
Fxx 12 1,5	230 VAC / 630 mA 16W	115 VAC / 315 mA 11W	24 VAC / 2 AT 10W
Fxx 10 2,2	230 VAC / 630 mA 16W	115 VAC / 315 mA 11W	
Fxx 07 03	230 VAC / 630 mA 16W	115 VAC / 315 mA 11W	24 VAC / 2 AT 10W
Fxx 07 05	230 VAC / 800 mA 16W	115 VAC / 500 mA 13W	
Fxx 05 05	230 VAC / 630 mA 16W	115 VAC / 315 mA 11W	24 VAC / 2 AT 10W
Fxx 06 06	230 VAC / 800 mA 16W	115 VAC / 500 mA 13W	
Fxx 05 07	230 VAC / 800 mA 16W	115 VAC / 500 mA 13W	
Fxx 10 05	230 VAC / 800 mA 19W		
Fxx 05 10	230 VAC / 800 mA 19W		
Fxx 05 0,2	230 VAC / 630 mA 16W	115 VAC / 315 mA 11W	
Fxx 03 11	230 VAC / 800 mA 19W		
Fxx 03 6,5	230 VAC / 630 mA 16W		
Fxx 03 8,5	230 VAC / 800 mA 16W		
FAxx 10 3,2	230 VAC / 800 mA 19W		
FAxx 10 0,6	230 VAC / 630 mA 16W		
FAxx 07 1,5	230 VAC / 630 mA 16W		
FAxx 05 3,7	230 VAC / 630 mA 16W		
FAxx 03 6,5	230 VAC / 800 mA 16W		
FAxx 03 4,7	230 VAC / 630 mA 16W		

During normal operating mode, pump must be checked once for month. Wear needed safety devices and check hoses and all hydraulic components for:

- product leak
- broken hoses
- corroded connections

All maintenance operations must be performed by authorized and trained personnel only. If pump needs factory assistance please use original package to return it.

Before to do it, please, remove all dosing product inside the pump and hoses.

Use only original spare parts!

B Appendix. Construction Materials and Technical info

TECHNICAL FEATURES

Power supply:	230 VAC (180-270 VAC)
Power supply:	115 VAC (90-135 VAC)
Power supply:	24 VAC (20-32 VAC)
Power supply:	12 VDC (10-16 VDC)
Pump strokes:	0 ÷ 150
Suction Height:	1,5 metres
Environment Temperature:	0 ÷ 45°C (32 ÷ 113°F)
Chemical Temperature:	0 ÷ 50°C (32 ÷ 122°F)
Installation Class:	II
Pollution Level:	2
Audible Noise:	74dbA
Packaging and Transporting Temperature:	-10 ÷ +50°C
Protection degree	IP65

MANUFACTURING MATERIALS

Case:	PP
Pump head:	PP, PVDF, PMMA, SS *
Diaphragm:	PTFE
Balls:	CERAMIC, GLASS, PTFE, SS *
Suction Pipe	PVC/PE **
Delivery Pipe:	PE
Valve Body:	PP, PVDF, SS *
O-ring:	FP, EP, WAX, SI, PTFE *
Injection connector	PP, PVDF (ceramic, HASTELLOY C276 spring)
Level Probe:	PP, PVDF *
Level probe cable:	PE
Foot Filter:	PP, PVDF *

* as ordered.

** according with pump's model.

Flow	Max Capacity l/h	Max Pressure bar	Capacity l/h	Pressure bar	ml stroke	Strokes/ min	Hoses mm	Watt W	Shipping weight Kg
12 1,5	1,5	12	2,5	6	0,17	150	4 x 6	16 W	2,2
10 2,2	2,2	10	3	5	0,25	150	4 x 6	16 W	2,2
07 03	3	7	4	3,5	0,34	150	4 x 6	16 W	2,2
07 05	5	7	7	3,5	0,56	150	4 x 6	16 W	2,2
06 06	6	6	8	3	0,67	150	4 x 6	16 W	2,2
05 07	7	5	8	2,5	0,78	150	4 x 6	16 W	2,2
05 05	5	5	7	2,5	0,56	150	4 x 6	16 W	2,2
03 6,5	6,5	3	7,5	1,5	0,72	150	4 x 6	16 W	2,2
03 8,5	8,5	3	10,4	1,5	0,94	150	4 x 6	19 W	2,2
10 05	5	10	6,5	5	0,56	150	4 x 6	19 W	2,2
05 10	10	5	12	2,5	1,00	166	4 x 6	19 W	2,2
03 11	11	3	13,1	1,5	1,10	166	4 x 6	19 W	2,2
05 0,2	0,2	5	0,9	2,5	0,25	15	4 x 6	16 W	2,2

C Appendix. Delivery Curves

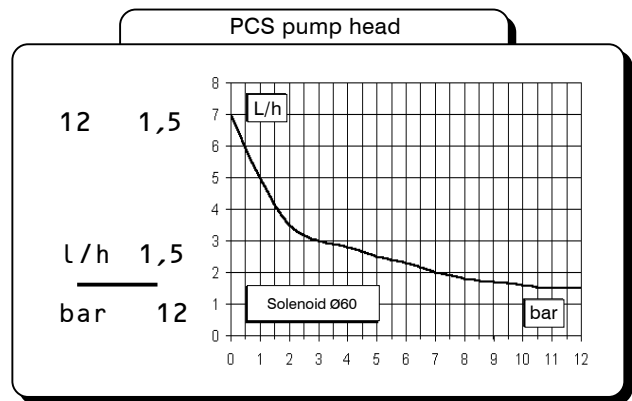
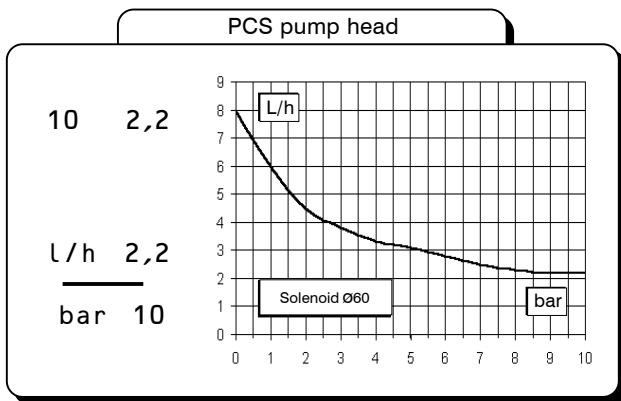
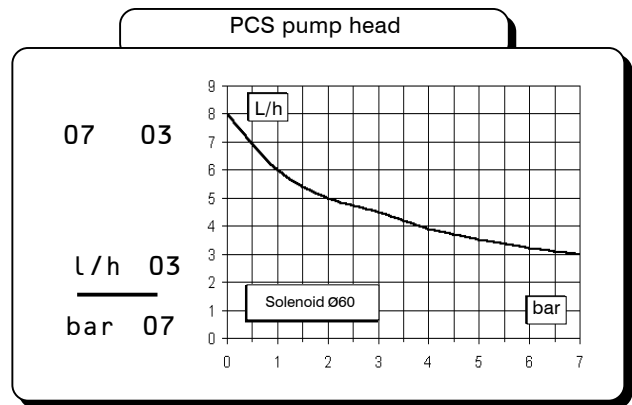
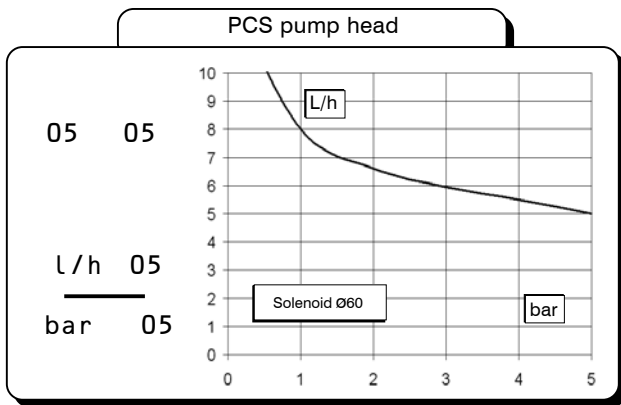
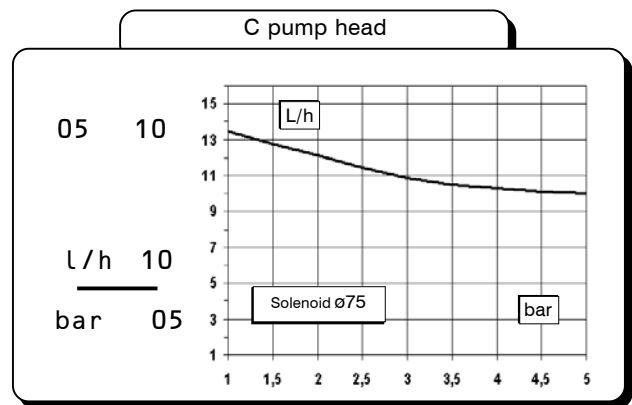
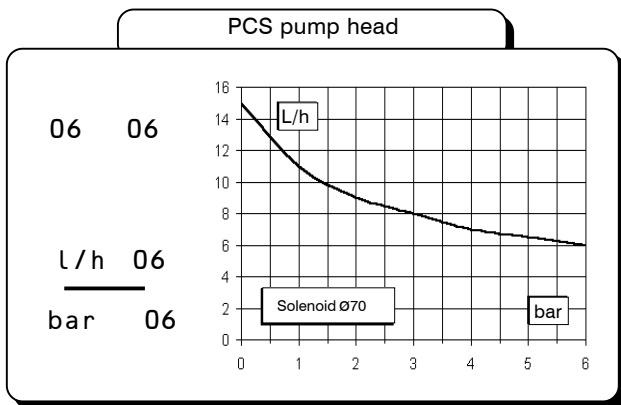
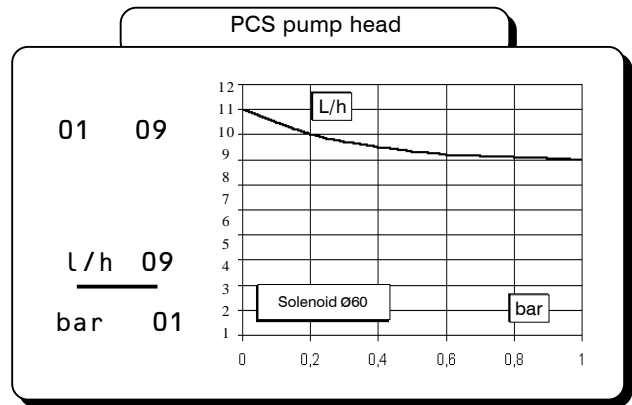
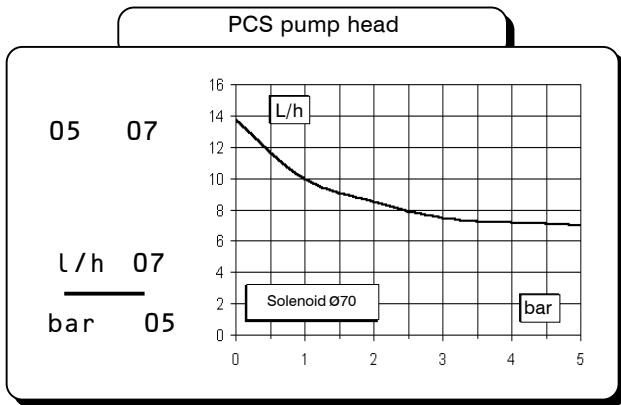

C Appendix. Delivery Curves

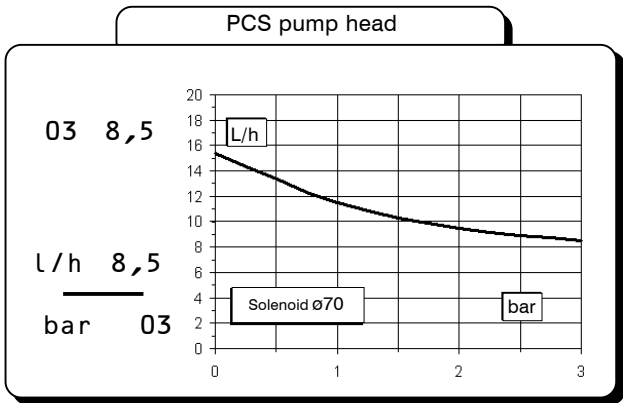
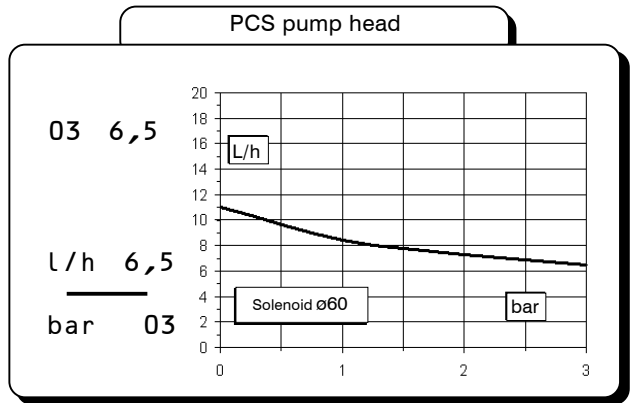
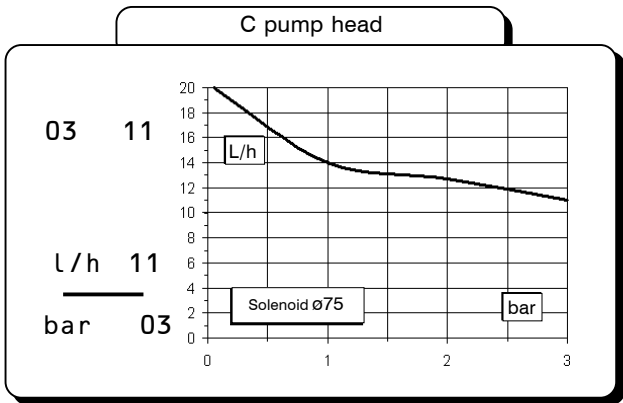
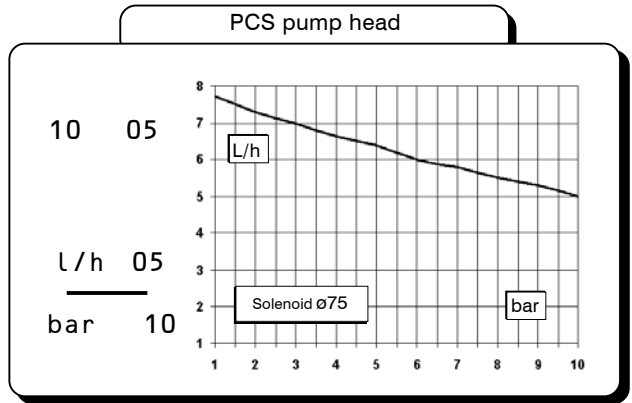
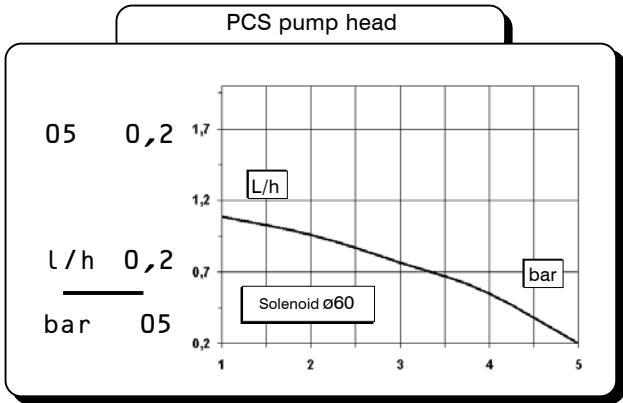
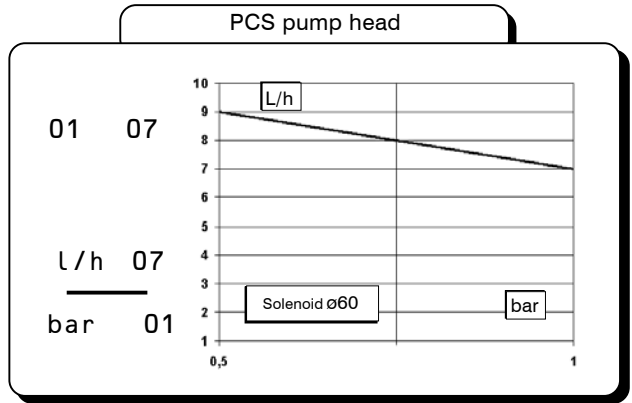
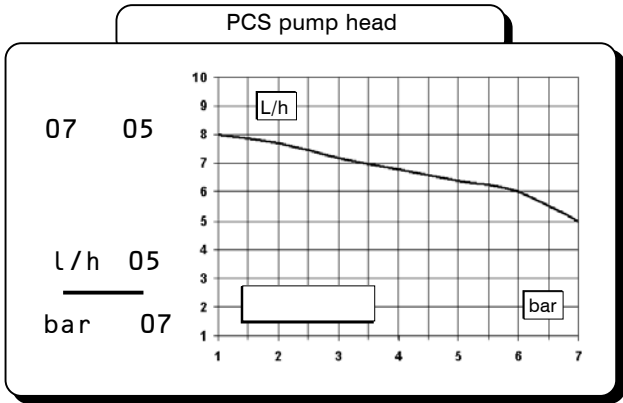

Flow rate indicated is for H₂O at 20°C at the rated pressure.
 Dosing accuracy ± 2% at constant pressure ± 0,5 bar.

C Appendix. Delivery Curves (Self Venting)

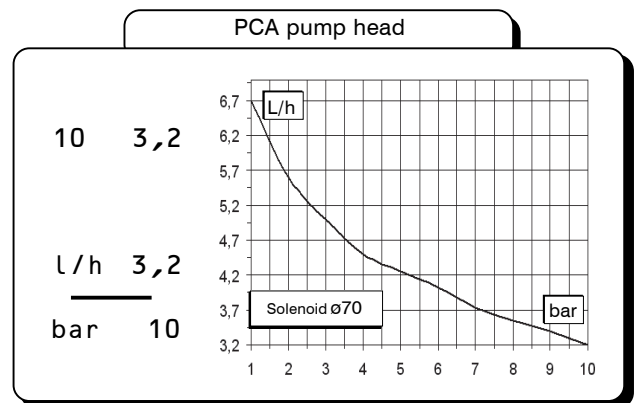
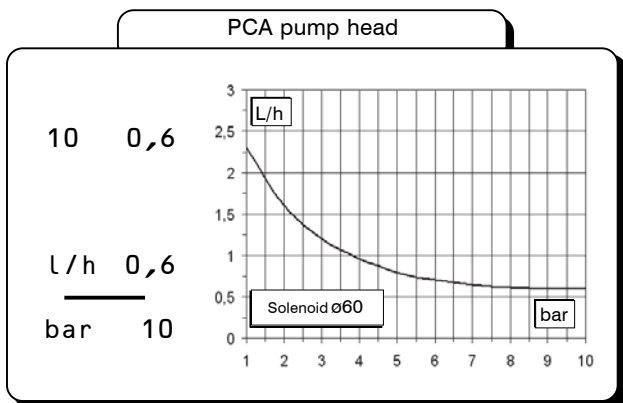
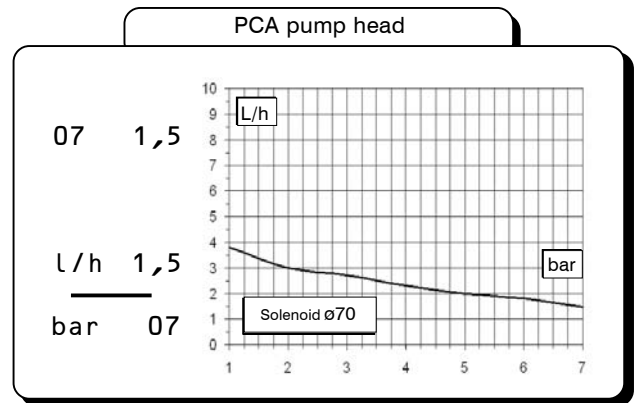
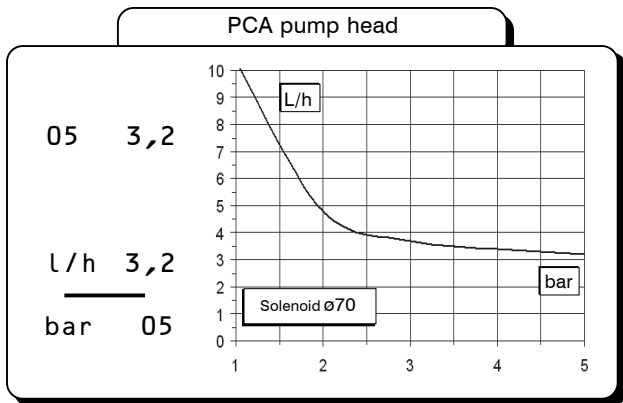
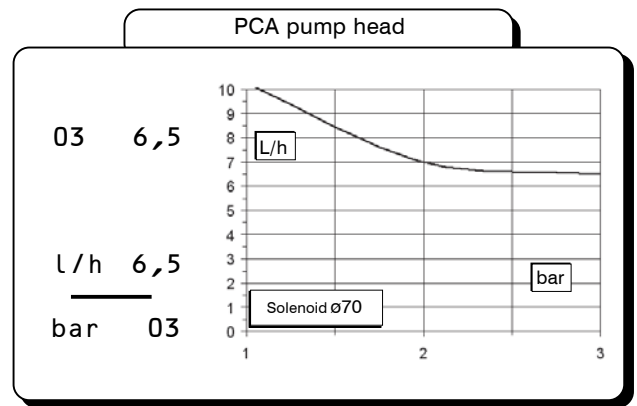
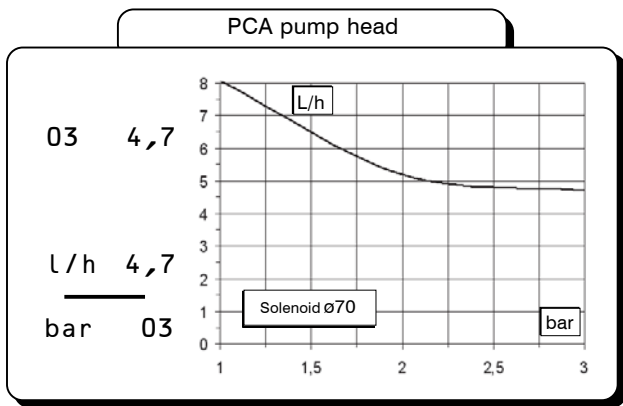

Dimensions

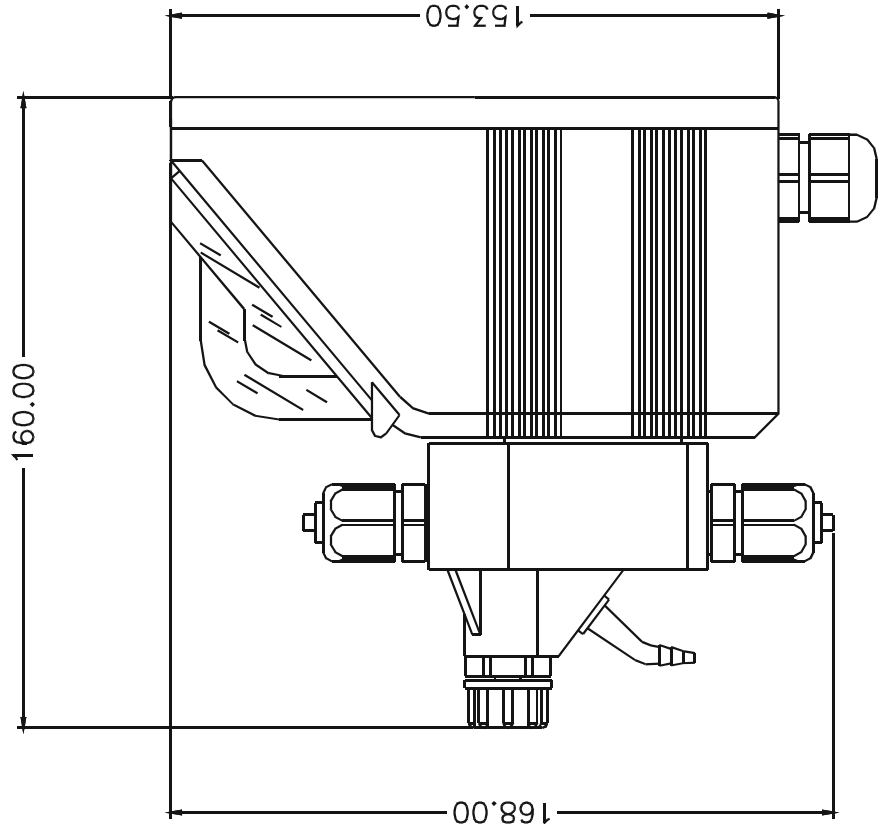
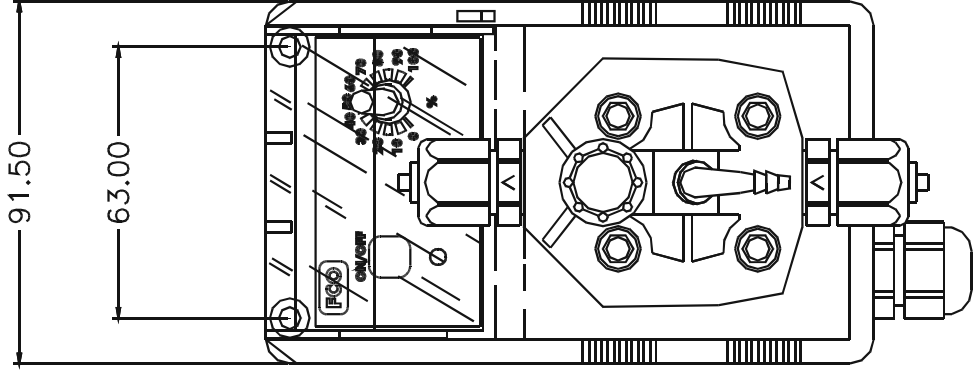

All measures are expressed in mm

E Appendix. Chemical Compatibility Table

Solenoid driven metering pumps are widely used to dose chemical fluids and it is important that the most suitable material in contact with fluid is selected for each application. This compatibility table serves as a useful help in this respect. All the informations in this list are verified periodically and believed to be correct on the date of issuance. All the informations in this list are based on manufacturer's data and its own experience but since the resistance of any material depends by several factors this list is supplied only as an initial guide, in no way EMEC makes warranties of any matter respect to the informations provided in this list.

Chemical	Formula	Glass	PVDF	PP	PVC	SS 316	PMMA	Hastelloy	PTFE	FPM	EPDM	NBR	PE
Acetic Acid, Max 75%	CH ₃ COOH	2	1	1	1	1	3	1	1	3	1	3	1
Aluminium Sulphate	Al ₂ (SO ₄) ₃	1	1	1	1	1	1	1	1	1	1	1	1
Amines	R-NH ₂	1	2	1	3	1	-	1	1	3	2	4	1
Calcium Hydroxide (Lime Milk)(Slaked Lime)	Ca(OH) ₂	1	1	1	1	1	1	1	1	1	1	1	1
Calcium Hypochlorite (Chlorinated Lime)	Ca(OCl) ₂	1	1	1	1	3	1	1	1	1	1	3	1
Copper-II-Sulphate (Roman Vitriol)	CuSO ₄	1	1	1	1	1	1	1	1	1	1	1	1
Ferric Chloride	FeCl ₃	1	1	1	1	3	1	1	1	1	1	1	1
Hydrofluoric Acid 40%	HF	3	1	1	2	3	3	2	1	1	3	3	1
Hydrochloric Acid, Concentrate	HCl	1	1	1	1	3	1	1	1	1	3	3	1
Hydrogen Peroxide, 30% (Perydrol)	H ₂ O ₂	1	1	1	1	1	3	1	1	1	2	3	1
Nitric Acid, 65%	HNO ₃	1	1	2	3	2	3	1	1	1	3	3	2
Phosphoric Acid, 50% (Orthophosphoric Acid)	H ₃ PO ₄	1	1	1	1	2	1	1	1	1	1	3	1
Potassium Permanganate, 10%	KMnO ₄	1	1	1	1	1	1	1	1	1	1	3	1
Sodium Bisulphite	NaHSO ₃	1	1	1	1	2	1	1	1	1	1	1	1
Sodium Carbonate (Soda)	Na ₂ CO ₃	2	1	1	1	1	1	1	1	2	1	1	1
Sodium Hydroxide (Caustic Soda)	NaOH	2	1	1	1	1	1	1	1	2	1	2	1
Sodium Hypochlorite, 12.5%	NaOCl + NaCl	1	1	2	1	3	1	1	1	1	1	2	1
Sulphuric Acid, 85%	H ₂ SO ₄	1	1	1	1	2	3	1	1	1	3	3	1
Sulphuric Acid, 98.5%	H ₂ SO ₄	1	1	3	3	3	3	1	1	1	3	3	3

Resistance rating

Resistant	1
Fairly resistant	2
Not resistant	3

Materials

Polyvinylidene fluoride	PVDF	Pump Heads, valves, fitting, tubing
Polypropylene	PP	Pump Heads, valves, fitting, level floater
PVC	PVC	Pump Heads
Stainless steel	SS 316	Pump Heads, valves
Polymethyl Metacrilate (Acrylic)	PMMA	Pump Heads
Hastelloy C-276	Hastelloy	Injection valve spring
Polytetrafluoroethylene	PTFE	Diaphragm
Fluorocarbon (Viton® B)	FPM	Sealings
Ethylene propylene	EPDM	Sealings
Nitrile	NBR	Sealings
Polyethylene	PE	Tubing

F Appendix. "F" and "FA" series pump installation drawings

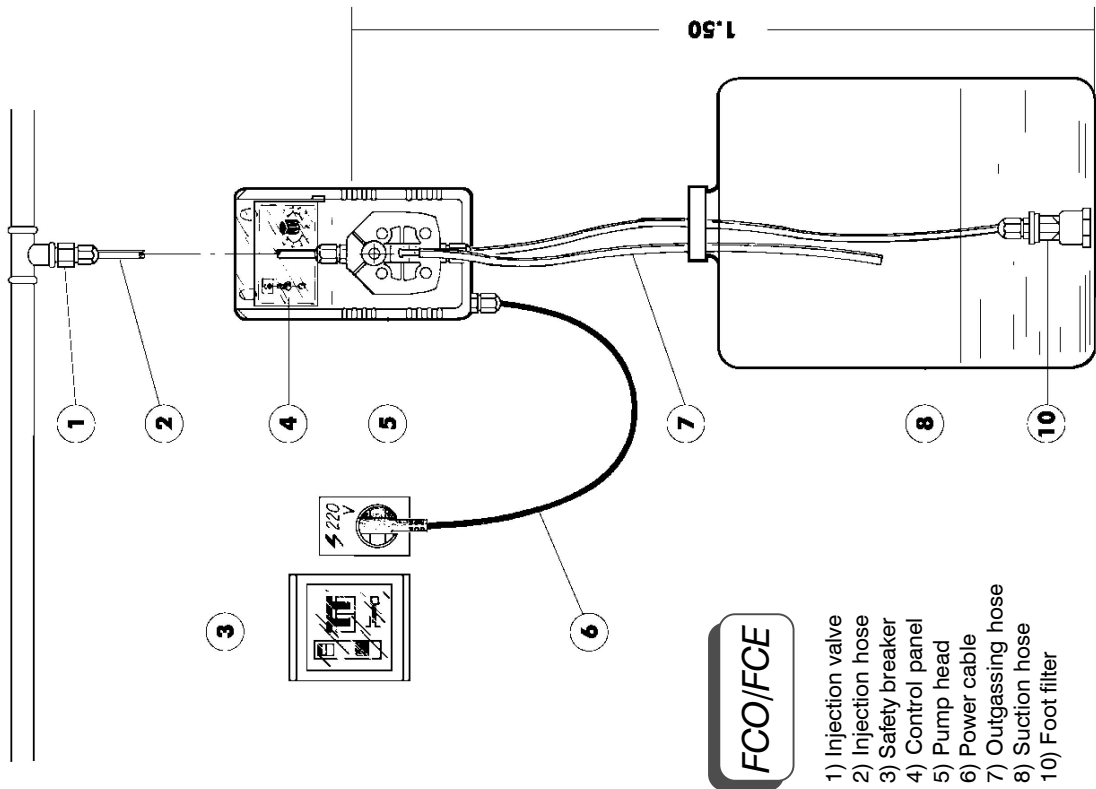
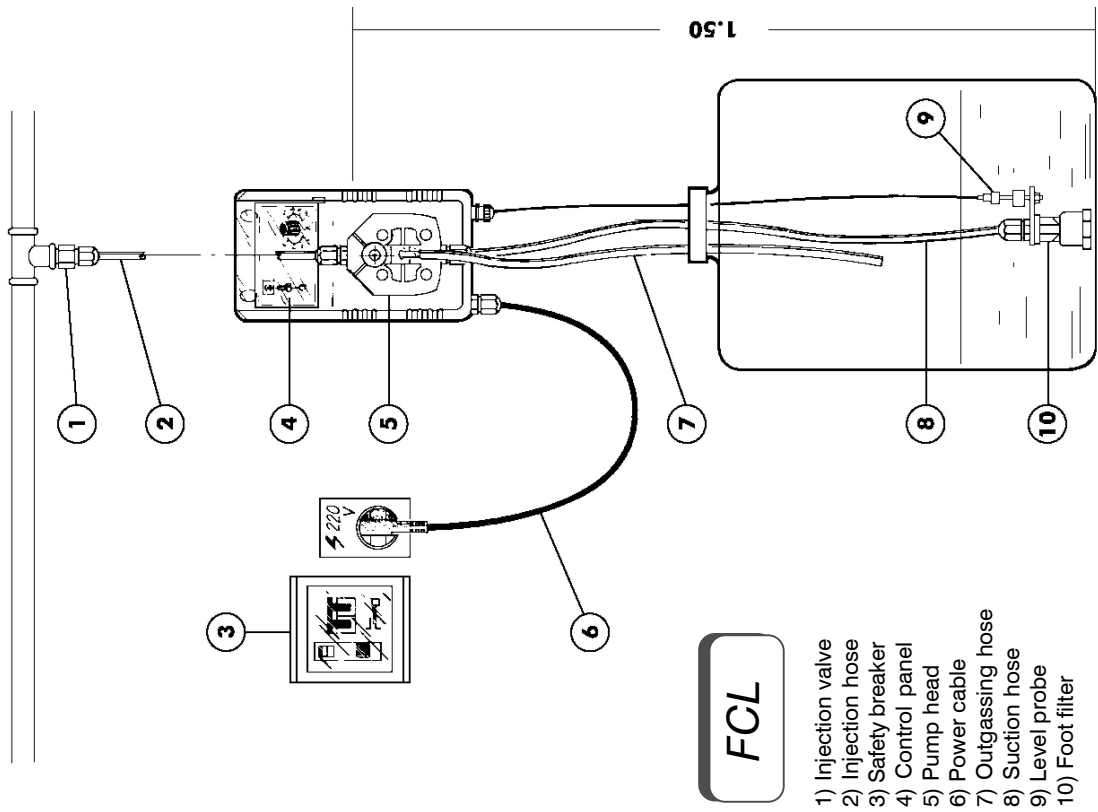

F Appendix. "F" and "FA" series pump installation drawings

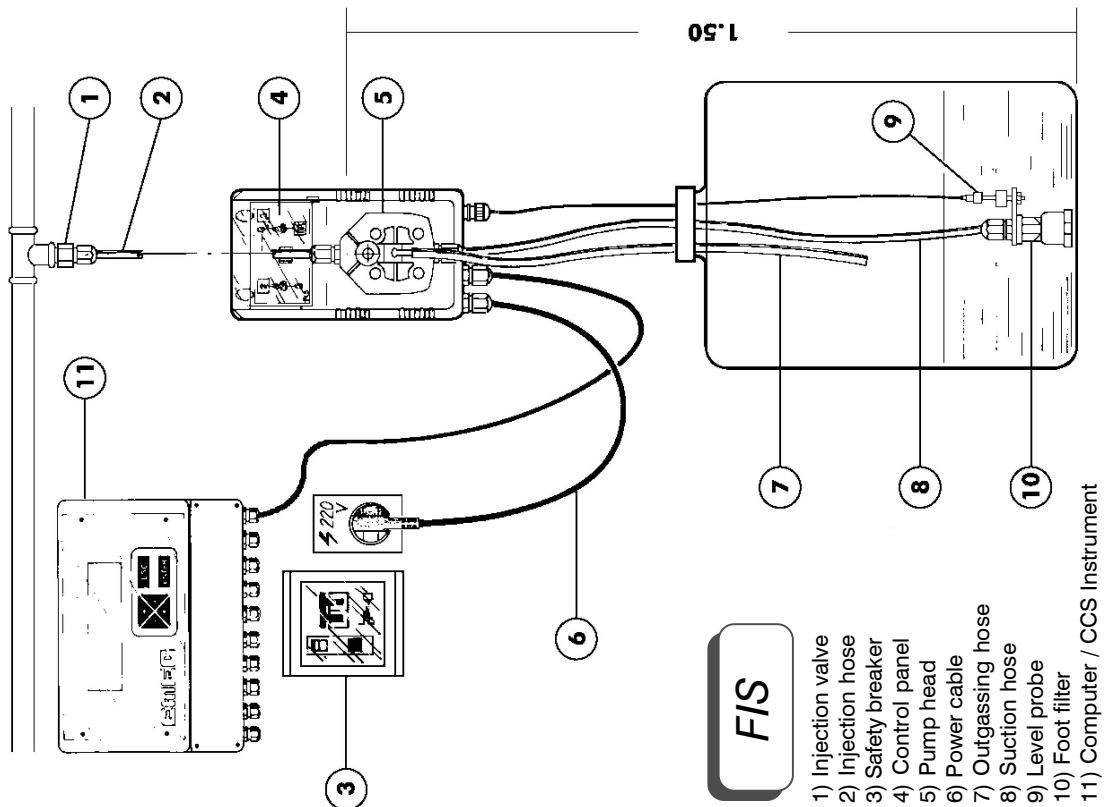
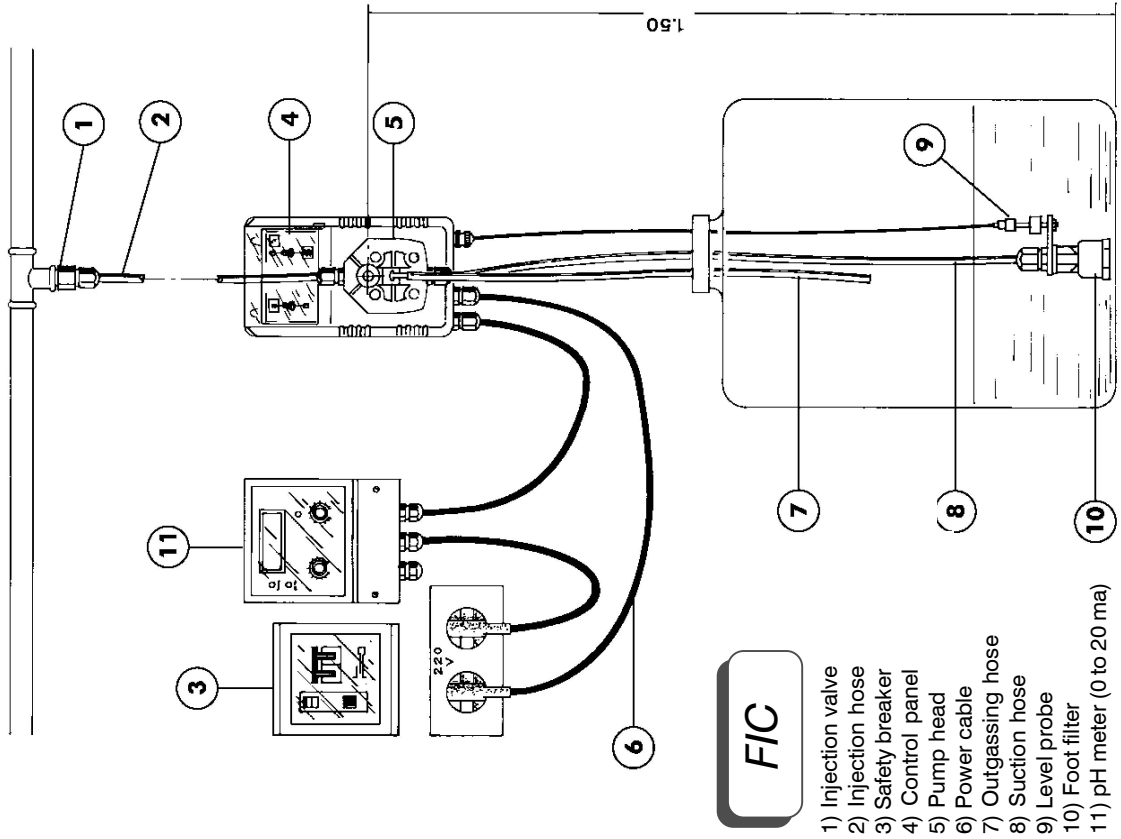

F Appendix. "F" and "FA" series pump installation drawings

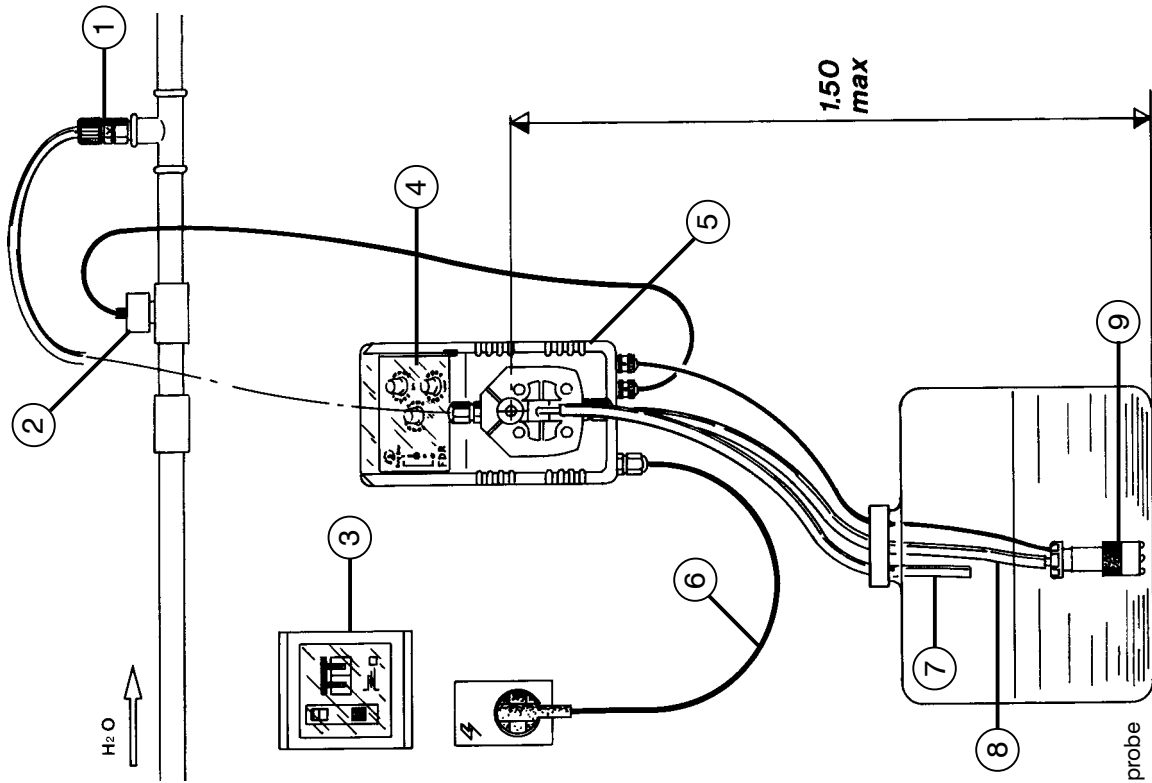

FDR

- 1) Injection valve
- 2) Electrovalve
- 3) Safety breaker
- 4) Control panel
- 5) Pump head
- 6) Power cable
- 7) Outgassing hose
- 8) Suction hose
- 9) Foot filter + level probe

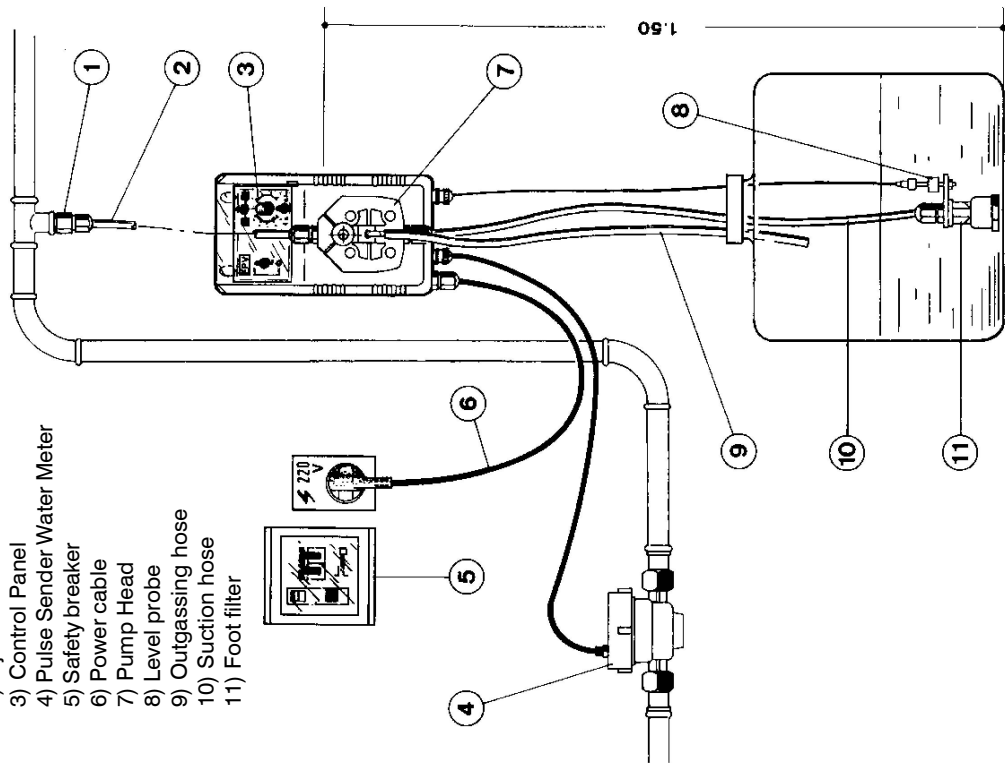

**FPV
FTE
FPVM**

- 1) Injection valve
- 2) Injection hose
- 3) Control Panel
- 4) Pulse Sender Water Meter
- 5) Safety breaker
- 6) Power cable
- 7) Pump Head
- 8) Level probe
- 9) Outgassing hose
- 10) Suction hose
- 11) Foot filter

G Appendix. "F" and "FA" series pump exploded view

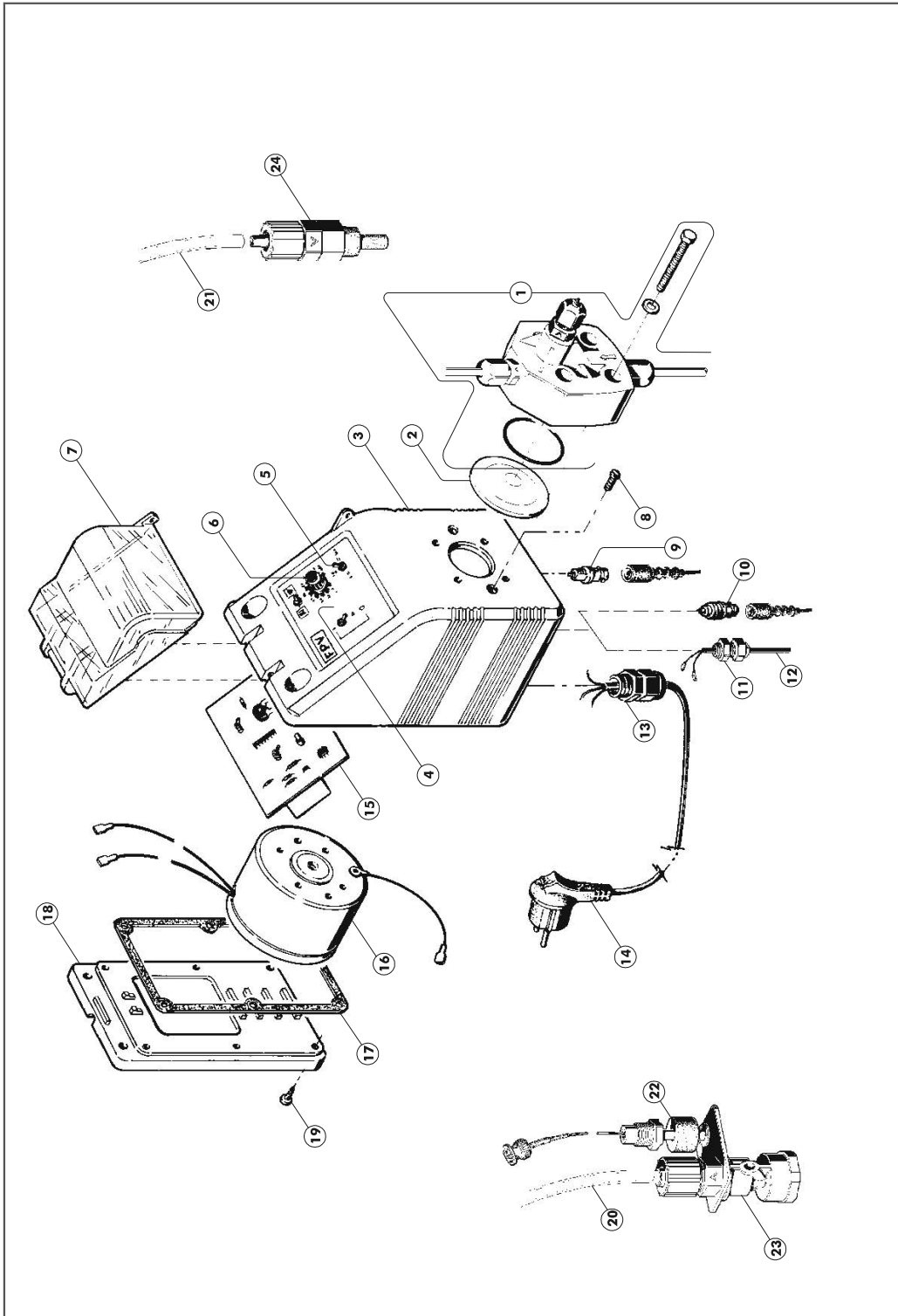

NOTICE: always specify the pump's label when ordering spare parts.

Summary

1. Introduction	3
2. Unpacking	4
3. General description	5
4. Before to Install warnings	6
5. Installation draw	7
6. Hydraulic Installation	8
7. Electrical installation	12
8. Models	14
9. Priming	24
10. Troubleshooting	25
11. Fuse and main board replacement	26
12. Main board	27
A Appendix. Maintenance.	29
B Appendix. Construction Materials and Technical info	30
C Appendix. Delivery Curves	31
C Appendix. Delivery Curves	32
C Appendix. Delivery Curves (Self Venting)	33
D Appendix. Dimensions	34
E Appendix. Chemical Compatibility Table	35
F Appendix. "F" and "FA" series pump installation drawings	36
G Appendix. "F" and "FA" series pump exploded view	39
H Appendix. Summary	43



Technical features and drawings are subject to changes and modifications without any advice.



*When dismantling a pump please separate material types and send them according to local recycling disposal requirements.
We appreciate your efforts in supporting your local Recycle Environmental Program.
Working together we'll form an active union to assure the world's invaluable resources are conserved.*